



Installation,
use and maintenance



(Copy of the original instructions)



SAFEGATE TRX IIII

Type 4 barrier for Access Control
with Muting functions integrated

SUMMARY

INTRODUCTION	5
PURPOSE OF THIS DOCUMENT	5
PRODUCT DESCRIPTION	5
CONTENT OF THE PACKAGE	5
GLOSSARY.....	6
DISPOSAL OF MATERIALS	6
SAFETY	7
SIMBOLOGY.....	7
PRECAUTIONS.....	7
CAUTIONS BEFORE INSTALLATION.....	8
LIST OF APPLICABLE STANDARDS	9
EC DECLARATION OF CONFORMITY.....	10
UKCA DECLARATION OF CONFORMITY.....	11
SYSTEM ARCHITECTURE	12
POSSIBLE CONFIGURATIONS (VIA OPTIONAL ACCESSORIES)	13
THE MUTING FUNCTION	16
A) 2 INTEGRATED CROSS MUTING SENSORS, ONLY FOR PALLET OUTPUTS (LX).....	17
B) 2 INTEGRATED PARALLEL MUTING SENSORS, ONLY FOR PALLET OUTPUTS (L2).....	18
C) 2 INTEGRATED CROSS MUTING SENSORS, FOR BI-DIRECTIONAL GATES (TX)	19
D) 4 INTEGRATED PARALLEL MUTING SENSORS, FOR BI-DIRECTIONAL GATES (T4)	20
<i>Concurrent</i>	20
E) 2 EXTERNAL CROSS INTEGRATED MUTING SENSORS, FOR BI-DIRECTIONAL GATES (TX).	21
F) 4 EXTERNAL PARALLEL MUTING SENSORS, FOR BI-DIRECTIONAL GATES (T4).	22
<i>Concurrent</i>	22
PARTIAL MUTING	23
<i>Partial Muting with Enable</i>	23
<i>Partial Muting with Disable</i>	23
MUTING OVERRIDE.....	24
<i>Override with Hold-to-run-Control</i>	24
<i>Override with Pulse Control</i>	24
MAXIMUM OVERRIDE TIME (MODELS WITH HARDWARE CONFIGURATION)	24
MAXIMUM OVERRIDE TIME (MODELS WITH SOFTWARE CONFIGURATION)	24
INSTALLATION	25
CALCULATION OF THE SAFETY DISTANCE.....	25
GENERAL FORMULA FOR CALCULATING THE SAFETY DISTANCE.....	25
MODELS WITH 2/3/4 BEAMS.....	26
MULTIPLE SYSTEMS	27
DISTANCE FROM REFLECTING SURFACES.....	28
MECHANICAL ASSEMBLY AND OPTICAL ALIGNMENT	29
SM - SMO MODELS ELECTRICAL CONNECTIONS	30
PRECAUTIONS	30
WARNINGS ON CONNECTION CABLES.....	30
ACTIVE ELEMENT CONNECTIONS.....	30
TEST FUNCTION	32
SELECTION OF OPERATING MODES.....	33
EDM.....	34
STATUS	34
OVERRIDE.....	35
OVERRIDE WITH HOLD-TO-RUN CONTROL	35
OVERRIDE WITH PULSE CONTROL	35
RESTART (MANUAL OPERATION).....	36

AUTOMATIC OPERATION	36
MUTING ENABLE	37
<i>Muting Enable active: correct Muting sequence</i>	37
APPENDIX A1: SM - SMO MODELS WIRING SAMPLES - MANUAL MODE	38
APPENDIX A2: SM - SMO MODELS WIRING SAMPLES - AUTOMATIC MODE	40
SMP - SMPO MODELS ELECTRICAL CONNECTIONS	42
PRECAUTIONS	42
WARNINGS ON CONNECTION CABLES	42
ACTIVE ELEMENT CONNECTIONS	42
<i>Available configurations</i>	42
TEST FUNCTION	44
SELECTION OF OPERATING MODES	45
EDM	45
STATUS	45
OVERRIDE (PC PROGRAMMING)	46
OVERRIDE WITH HOLD-TO-RUN CONTROL	46
OVERRIDE WITH PULSE CONTROL	46
RESTART (MANUAL OPERATION)	47
AUTOMATIC OPERATION	47
MUTING ENABLE	48
<i>Muting Enable active: correct Muting sequence</i>	48
MUTING ENABLE/DISABLE	48
<i>Muting Enable/Disable active: Correct Muting sequence</i>	48
PARTIAL MUTING	49
1) <i>Partial Muting with Enable (option not available for 2B Models)</i>	49
2) <i>Partial Muting with Disable (option not available for 2B Models)</i>	49
APPENDIX B: SMP - SMPO MODELS WIRING SAMPLE	50
S, SO MODELS ELECTRICAL CONNECTIONS	51
PRECAUTIONS	51
WARNINGS ON CONNECTION CABLES	51
ACTIVE ELEMENT CONNECTIONS	51
APPENDIX C: S, SO MODELS WIRING SAMPLES	53
S-A, SO-A MODELS ELECTRICAL CONNECTIONS	54
PRECAUTIONS	54
WARNINGS ON CONNECTION CABLES	54
ACTIVE ELEMENT CONNECTIONS	54
AUTOMATIC OPERATION	55
TEST FUNCTION	55
APPENDIX C: S-A, SO-A MODELS WIRING SAMPLES	56
LIGHT SIGNALS	57
ACTIVE ELEMENT SIGNALS (SM, SMO, SMP, SMPO)	57
ACTIVE ELEMENT SIGNALS (S, SO, S-A, SO-A)	58
ACTIVE ELEMENT SIGNALS (INTEGRATED LAMP)	59
ACTIVE ELEMENT - FAULT DIAGNOSIS	60
TECHNICAL SPECIFICATIONS	61
MECHANICAL DIMENSIONS	64
CURTAIN DIMENSIONS	64
ACCESSORY DIMENSIONS	67
SOFTWARE SAFEGATE CONFIGURATOR	70
SOFTWARE INSTALLATION	70
<i>HARDWARE characteristics requested by the PC for connection</i>	70

<i>SOFTWARE characteristics requested by the PC for connection</i>	70
<i>How to install SAFEGATE CONFIGURATOR</i>	70
CONFIGURATION PHASES	70
THE TOOLBAR	71
GRAPHICAL INTERFACE	72
<i>Level 1 password</i>	72
<i>Level 2 password</i>	72
CONNECTION WITH SAFEGATE	73
DOWNLOAD CONFIGURATION	73
CURTAIN PROGRAMMING	74
<i>Level 2 password</i>	74
CONFIGURATION VALIDATION AND LOADING	74
PRINT REPORT CONFIGURATION	75
CONFIGURATION HISTORY	75
LOG ERRORS DOWNLOAD	75
SAFEGATE ACTIVATION	76
CURTAIN CONDITION MONITORING	76
CONFIGURATION DELETION	76
SETTING CURTAIN GENERAL PARAMETERS	77
SETTING MUTING PARAMETERS	78
<i>"Concurrent" Muting</i>	78
<i>"Sequential" Muting</i>	79
<i>"L" Muting</i>	80
<i>"T" Muting</i>	81
PARTIAL MUTING	82
<i>Partial Muting with Enable</i>	82
<i>Partial Muting with Disable</i>	82
<i>Partial Muting: MONITOR</i>	82
MUTING OVERRIDE	83
<i>Override with Hold-to-run control</i>	83
<i>Override with Pulse control</i>	83
SAFEGATE DIAGNOSTIC - ERRORS	84
CONTROLS, CARE AND MAINTENANCE	85
PRE-ACTIVATION CHECKLIST	85
PERIODIC CONTROL	85
CARE AND MAINTENANCE	86
WARRANTY	87

INTRODUCTION

Dear customer, REER congratulates you on purchasing this product. Refer to this manual before using SAFEGATE; keep this manual (printed or PDF) and the Quick Installation Guide in an accessible place for future consulting when necessary.

PURPOSE OF THIS DOCUMENT

This manual illustrates the operation of the programmable access curtain with Muting integrate SAFEGATE functions. It shows specifically:

- a general description of the SAFEGATE world;
- the characteristics of the muting function;
- the different types of muting and their application;
- the list of SAFEGATE models;
- the mechanical installation;
- the electrical connections;
- the mode of operation;
- the Muting, Override modes and their activation;
- SAFEGATE programming through dedicated software.

PRODUCT DESCRIPTION

The SAFEGATE light curtain is an optoelectronic multi-beam safety system belonging to the category of Type 4 electro-sensitive devices (in accordance with EN 61496-1,2), equipped with the Muting function, for the protection of persons exposed to dangerous machines or plants.

SAFEGATE ensures a perfect integration of the Muting sensors that are connected directly to the connectors on the safety curtain.

In the hardware configuration models (SM and SMO) the Muting logic and the operating parameters are fully defined by the connections of the main connector.

The SMPO programmable models retain all the features of SM and SMO models allowing also the configuration of various parameters and additional features via the SCS software (SAFEGATE Configuration Software).

The main features of SAFEGATE are as follows:

- 2, 3 and 4 beams.
- Beams pitch: 300mm (4 beams), 400mm (3 beams), 500mm (2 beams)
- Integration of the main safety functions, including self-monitoring of static outputs, EDM and Start/Restart Interlock.
- Outline dimensions: 55 x 50 mm.
- Degree of protection: IP65 e IP67.
- Operating temperature: -30 ... +55 ° C (no condensation).
- Muting lamp and integrated curtain status indication (SMO/SMPO).

CONTENT OF THE PACKAGE

- SAFEGATE active and passive element
- Quick Installation Guide
- Mounting accessories bag
- Sealing caps for unused connectors

GLOSSARY

PROTECTED HEIGHT	A measure that indicates the height controlled by the curtain.
SAFETY DISTANCE	Minimum distance that must exist between the protected gate and the dangerous area
EDM	External Device Monitoring: control of external contactors switching through the feedback input.
MUTING	Function of temporary suspension of the safety function: temporary exclusion of the safety curtain, automatically and safely carried out based on the machine cycle.
OVERRIDE	Forced activation of OSSD outputs: during the muting cycle for material removal
RANGE	Maximum operating distance: between active and passive elements
BEAMS PITCH	Distance from the center of two adjacent beams
START/RESTART INTERLOCK	Interlock function (manual reset required): when starting or restarting the machine
RESPONSE TIME	Time: between interruption of the gate and disabling of outputs
LX	Muting Logic with 2 mono-directional cross-sensors
L2	Muting Logic with 2 mono-directional parallel sensors
TX	Muting Logic with 2 bi-directional cross-sensors
T4	Muting Logic with 4 bi-directional parallel sensors
S, S-A	Models without Muting
SO, SO-A	Models without Muting, with integrated lamp
SM	Model with Muting and Hardware configuration on main connector
SMO	SM model with integrated Muting lamp
SMP	Model with Muting Programmable with SCS software
SMPO	SMP model with integrated Muting lamp

DISPOSAL OF MATERIALS

Dispose of the product in an eco-compatible manner and in accordance with national legislation.



For Countries in the European Union:

Pursuant to the Directive no. 2012/19/EU on waste electrical and electronic equipment (WEEE).

The crossed out wheeled-bin symbol on the equipment or its packaging means that when the product reaches the end of its useful life it must be collected separately from other waste.

Proper separate collection of the discarded equipment for later environment-friendly recycling, processing and disposal, helps to avoid any negative impact on the environment and health and encourages re-use and recycling of the materials the equipment is made of.

In each individual Member State of the European Union this product is required to be disposed of in accordance with Directive **2012/19/EU** as implemented in the Member State where the product is disposed of. For further information please contact REER or your local dealer.

SAFETY

SIMBOLOGY

 *This symbol indicates an important warning for personal safety. Failure to comply with this warning may result in high level risk for exposed personnel.*

 *This symbol indicates an important warning for the proper operation of the curtain.*

PRECAUTIONS

 *The operations indicated in this document must only be carried out by qualified personnel. Such personnel must have the necessary requirements to be able to operate on the electronic equipment to be installed in order to avoid any risky situation.
REER declines any liability for malfunctioning of equipment installed by unqualified staff.*

 *Any use other than those indicated in this manual may be considered as potentially dangerous for the installer and the machine operator.*

 *For safety reasons, please contact your country's safety authorities or the relevant industry association if necessary.*

 *For applications in the food industry, consult the manufacturer to verify compatibility between curtain materials and chemical agents used.*





 *The protective function of optoelectronic safety devices is not effective in cases where:*

- The machine stopping device cannot be actuated electrically and it is not possible to stop all dangerous machine movements immediately and at any time during the operating cycle.
- The hazardous condition is associated with the falling of objects from above or ejection of these from the machine.
- Anomalous forms of light radiation are present (for example, use of cableless control devices on cranes, radiation from weld spatter, etc). In this case additional measures may be necessary to ensure that the ESPE does not fail to danger.

 *The strict and complete observance of all the standards, indications and prohibitions set forth in this manual is a prerequisite for its proper operation.
REER S.p.A. therefore, declines any liability in case of non-respect, even partial, of these indications.*

CAUTIONS BEFORE INSTALLATION



Before installing the SAFEGATE safety system, you must verify all of the conditions listed below:

-  *The protection level (Type4, SIL3, SILCL3, PLe) of the SAFEGATE system must be compatible with the danger level of the system to be controlled.*
-  *The safety system should only be used as a stop device and not as a device for controlling the machine.*
-  *The machine control must be electrically actuated.*
-  *It must be possible to immediately stop any dangerous operation of the machine. In particular, the machine stopping times must be known and, if necessary, measured.*
-  *The machine must not generate hazardous situations due to projection or fall of materials from above; otherwise it is necessary to provide additional mechanical protections.*

The knowledge of the shape and size of the hazardous area allows an estimation of the width and the height of its access area:

-  *Compare these dimensions with the maximum working range and the height of the area guarded by the model used.*

Before placing the safety device, it is important to consider the following general guidelines:

-  *Verify that the temperature of the environment where the system is installed is compatible with the temperature operating parameters indicated on the product label and in the technical data.*
-  *Avoid positioning Active and Passive elements near intense or flashing high-intensity light sources.*
-  *Specific environmental conditions may affect the level of detection of photoelectric devices. In environments where fog, rain, smoke or dust may be present, it is advisable to use suitable Fc correction factors at the maximum useful values of the working range to ensure the correct operation of the equipment. In these cases:*

$$\underline{\underline{P_u = P_m \times F_c}}$$

where P_u and P_m are respectively the working range and maximum range in metres.

Recommended F_c factors are shown in the following table.

ENVIRONMENTAL CONDITION	CORRECTION FACTOR F_c
Fog	0,25
Steam	0,50
Powders	0,50
Dense smoke	0,25

-  *If the device is placed in environments subject to sudden temperature fluctuations, it is imperative to take the appropriate steps to avoid condensation on the lenses, which may impair the detection capability.*

LIST OF APPLICABLE STANDARDS

SAFEGATE is manufactured in compliance with the following European Directives:

2006/42/EC "Machinery Directive"

2014/30/EU "Electromagnetic Compatibility Directive"

And it complies with the following Standards:

Safety level	Type 4	<ul style="list-style-type: none">➤ EN 61496-1:2013➤ EN 61496-2:2013
	SIL 3	<ul style="list-style-type: none">➤ IEC 61508-1:(ed.2)➤ IEC 61508-2:(ed.2)➤ IEC 61508-3:(ed.2)➤ IEC 61508-4:(ed.2)
	SILCL 3	<ul style="list-style-type: none">➤ IEC 62061:2005/A2:2015
	PL e - Cat. 4	<ul style="list-style-type: none">➤ EN ISO 13849-1: 2015

EC DECLARATION OF CONFORMITY**Dichiarazione CE di conformità**
EC declaration of conformity

Torino, 14/09/2022

REER SpA
via Carcano 32
10153 – Torino
Italy

dichiara che le barriere fotoelettriche SAFEGATE sono Dispositivi Elettrosensibili di Sicurezza (ESPE) di :

- **Tipo 4** (secondo la Norma EN 61496-1:2013; EN 61496-2:2013)
- **SIL 3** (secondo la Norma EN 61508-1:2010; EN 61508-2:2010; EN 61508-3:2010; EN 61508-4:2010)
- **SILCL 3** (secondo la Norma EN 62061:2005/A2:2015)
- **Cat.4 - PL e** (secondo la Norma EN ISO 13849-1:2015)

declares that the SAFEGATE photoelectric safety barriers are :

- **Type 4** (according the Standard EN 61496-1:2013; EN 61496-2:2013)
- **SIL 3** (according the Standard EN 61508-1:2010; EN 61508-2:2010; EN 61508-3:2010; EN 61508-4:2010)
- **SILCL 3** (according the Standard EN 62061:2005/A2:2015)
- **Cat.4 - PL e** (according the Standard EN ISO 13849-1:2015)

Electro-sensitive Protective Equipments (ESPE)

realizzati in conformità alle seguenti Direttive Europee:
complying with the following European Directives:

- **2006/42/EC** "Direttiva Macchine"
"Machine Directive"
- **2011/65/EU** "RoHS – Linea Guida"
"RoHS – Guideline"
- **2014/30/EU** "Direttiva Compatibilità Elettromagnetica"
"Electromagnetic Compatibility Directive"

e alle seguenti Norme: /and to the following Standards:

- **EN 50178: 1997**
- **EN 55032: 2015**
- **EN 61000-6-2: 2005**

e sono identiche all'esemplare esaminato ed approvato con esame di tipo CE da:

*and are identical to the specimen examined and approved with a CE - type approval by:***TÜV SÜD Product Service GmbH – Zertifizierstelle – Ridlerstraße 65 – 80339 – München – Germany**
N.B. number: 0123 - Certificate No: Z10 024820 0083 Rev.01Responsabile per la documentazione tecnica:
Responsible person for technical documentation:

Carlo Pautasso

Carlo Pautasso
Direttore Tecnico
Technical Director**Simone Scaravelli**
Amministratore Delegato
Managing Director

UKCA DECLARATION OF CONFORMITY

ReeR declares that SAFEGATE TRX photoelectric safety barriers complies with following UK legislation:

- S.I. 2008 No. 1597 - The Supply of Machinery (Safety) Regulations
- S.I. 2016 No. 1101 - Electrical Equipment (Safety) Regulations
- S.I. 2016 No. 1091 - Electromagnetic Compatibility Regulations
- S.I. 2012 No. 3032 - The Restriction of the Use of Certain Hazardous Substances in Electrical and Electronic Equipment Regulations

➔ ***Please refer to the link: <https://www.reersafety.com/certifications/> to download the complete UKCA Declaration of Conformity.***

SYSTEM ARCHITECTURE

SAFEGATE is supplied as a pair (Active and Passive element) and allows integration with external Muting sensors that are directly connected to the connectors installed on the curtain.

- Each curtain can be configured as LX, L2, TX and T4 (see the different Muting types in the section “MUTING FUNCTION”) through the wiring of the main connector. This configuration can be changed at any time.
- SAFEGATE can be used with (pre-aligned and pre-configured) Muting arms, with M TRX photocells (available as accessories) or any other Muting sensor.
- **S-A** models provide Automatic operation (without “START/RESTART INTERLOCK”, “EDM” and Muting function).
- **S** models integrate the functions of “START/RESTART INTERLOCK” and “EDM” but do not allow the Muting function.
- **SM** models allow the Muting function, but have no integrated signal lamp.
- Programmable **SMP**
- models allow an ideal use of further configuration options to solve potential problems in complex application scenarios.
- **SO, SO-A, SMO, SMPO** models with Integrated signalling lamp allow the immediate viewing of the curtain status even at a distance.

PLEASE NOTE

The sample figure represents the Active Element of a SMPO model.

This model comes with integrated signal lamp. Furthermore, the configuration connector allows the USB connection to a PC with the configuration software installed.

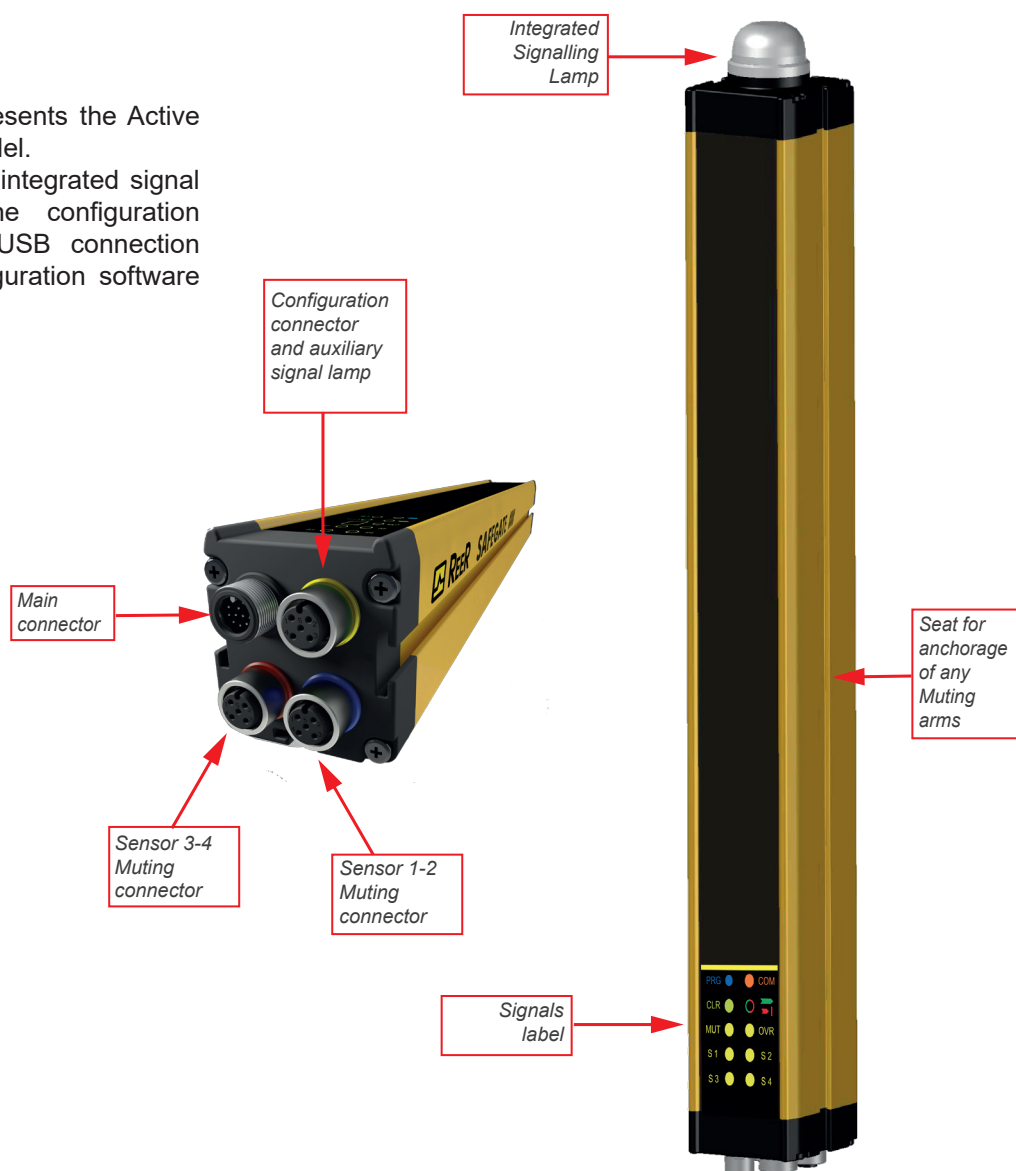

POSSIBLE CONFIGURATIONS (via optional accessories)

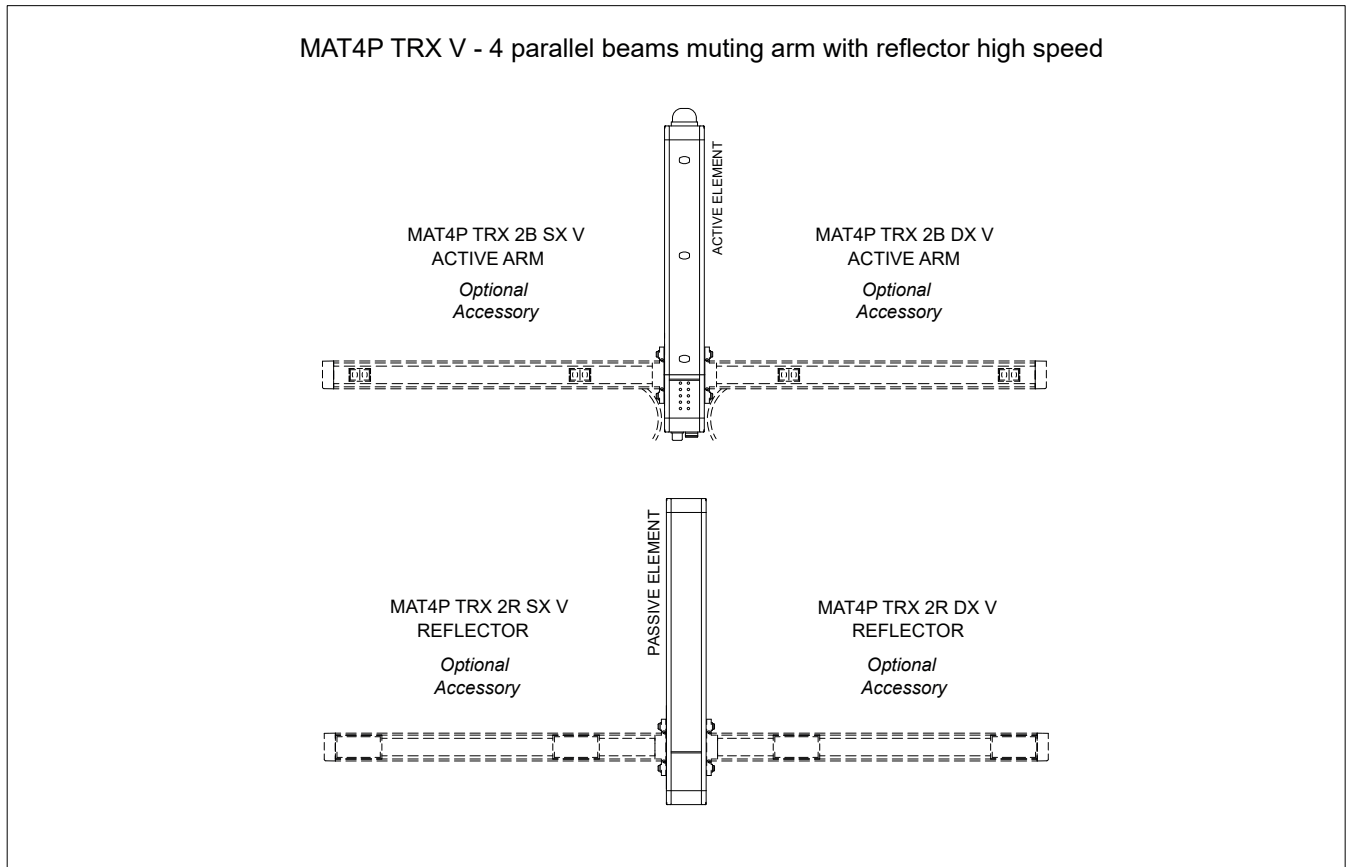
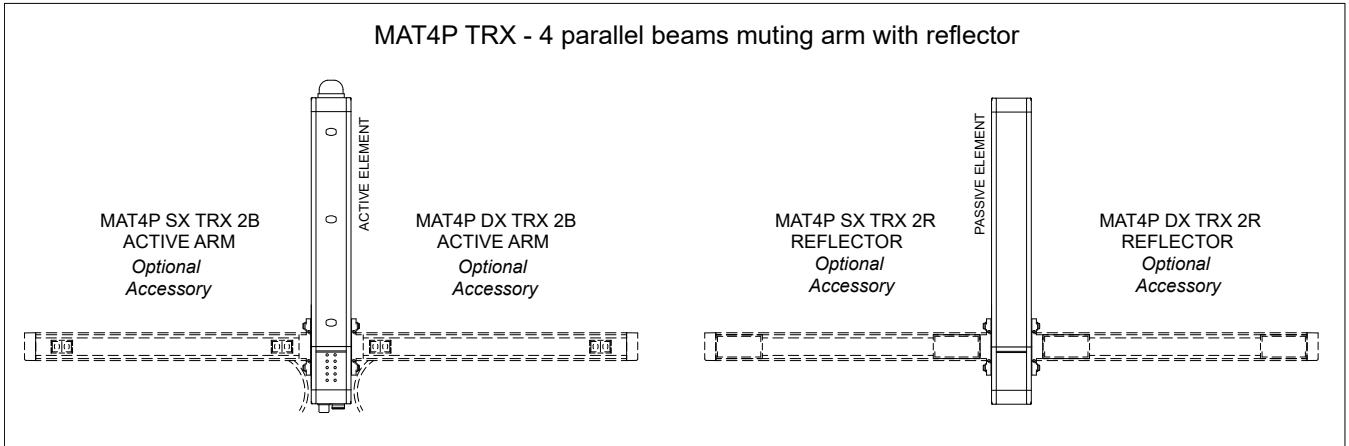

MAL2P TRX - 2 parallel beams muting arm with reflector

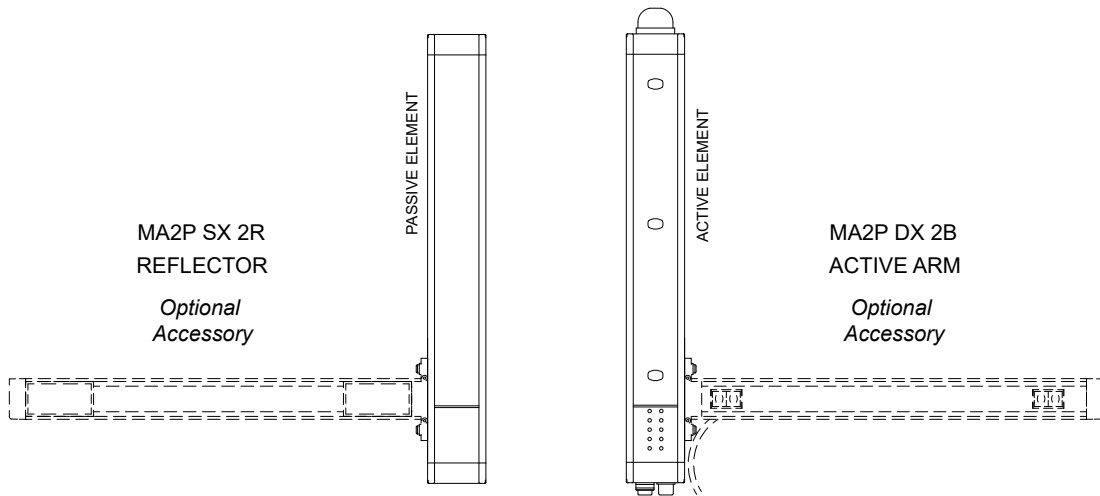

MAT4P TRX / MAT4P G - 4 parallel beams muting arm with reflector

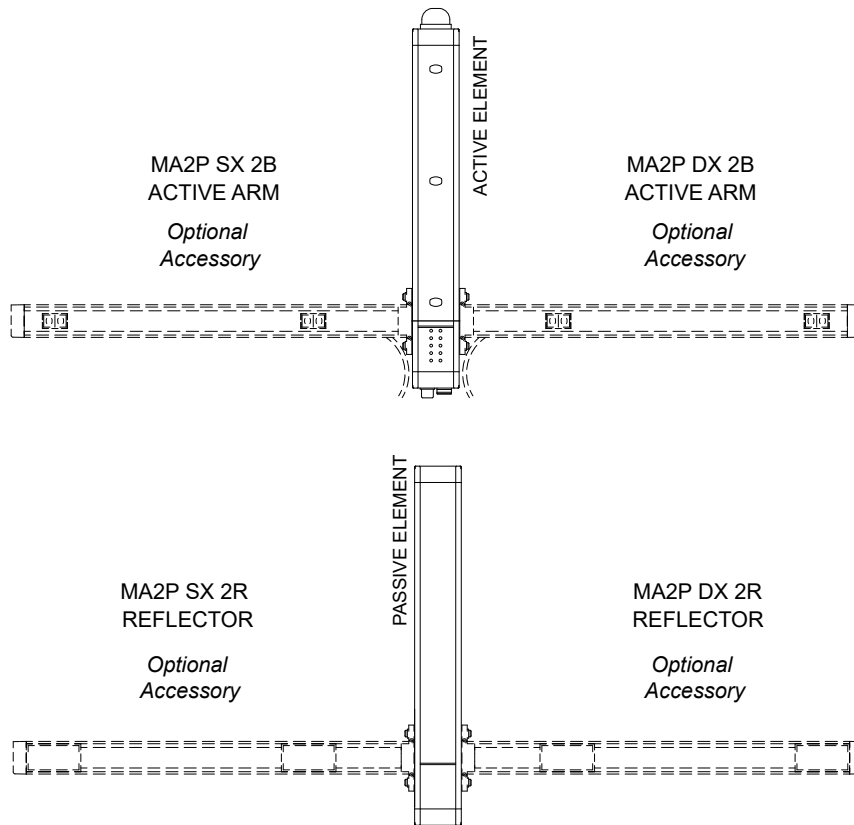

8541205 - rev.7 - 10/07/2023

MZL2XP TRX - 2 crossed / parallel adjustable beams M TRX muting arms

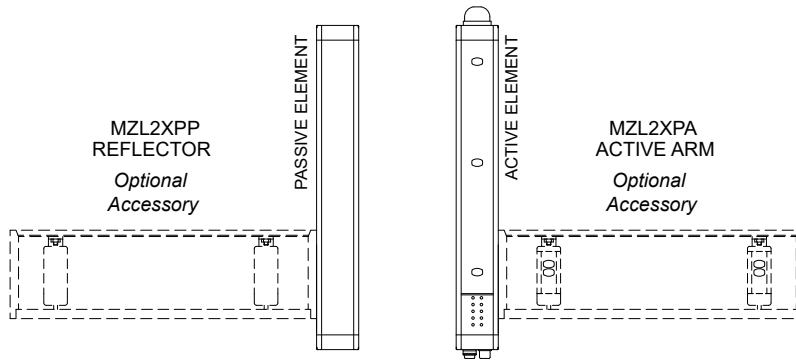

MZT2X TRX - 2 crossed beams M TRX muting arms

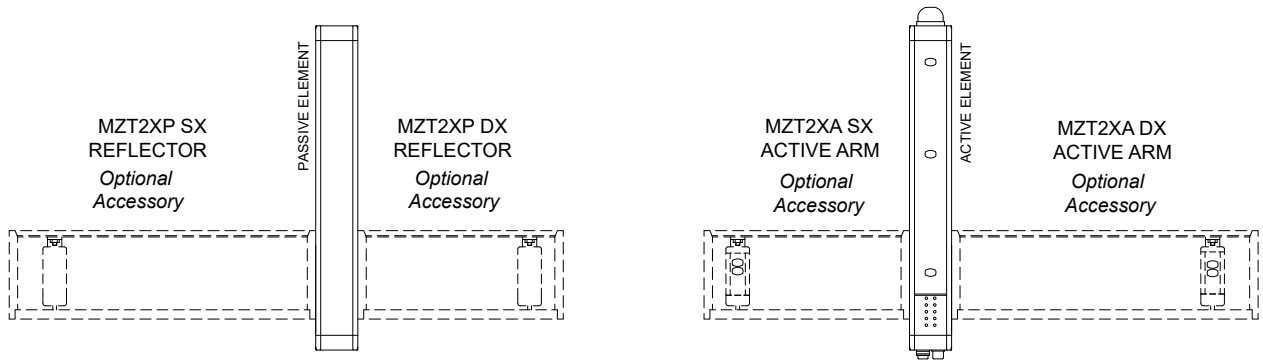

MZT4P TRX - 4 parallel beams M TRX muting arms

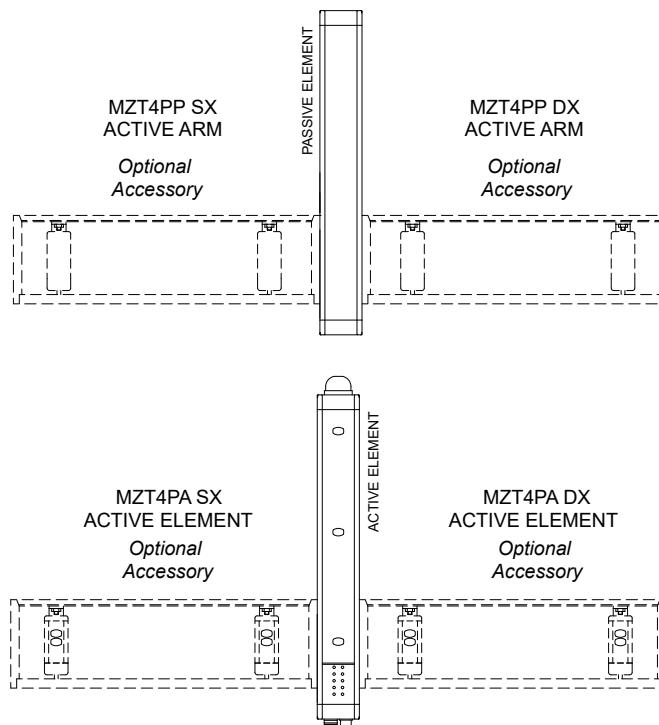

THE MUTING FUNCTION

The Muting function is the temporary exclusion of the safety curtain, automatically and safely carried out based on the machine cycle.

➔ **Carefully verify your risk analysis to make sure the Muting function is compatible with your application and what additional measures should be taken.**

There are basically two types of applications:

1. Those allowing people to enter the dangerous area during the non-dangerous part of the machine cycle.

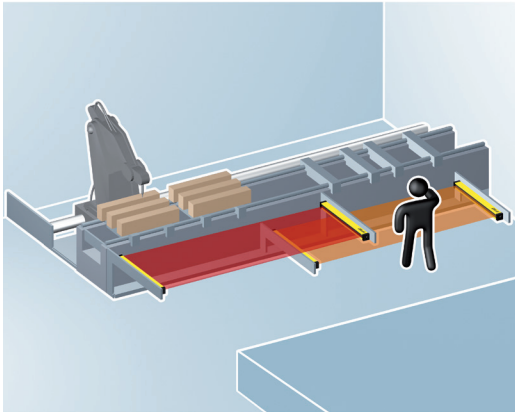

Example: Positioning or Removing the workpiece

Depending on the position of the tool, which is the hazardous element, one of the two curtains (the one facing the tool work area) is active while the other is in Muting condition to allow the operator loading/unloading the workpiece. The Muting condition of the two curtains will then be reversed when the tool is to work on the opposite side of the machine.

2. Those who allow material transit and prevent access to the people.

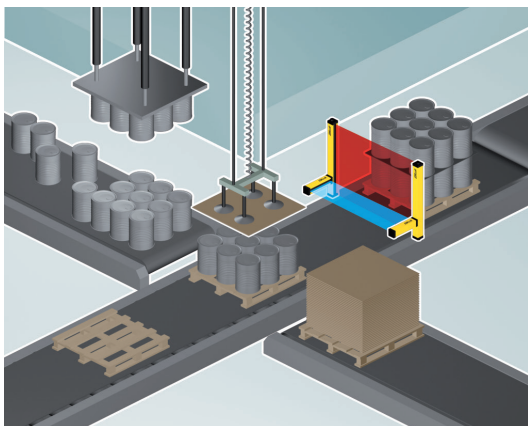

Example: Pallet exit from the hazardous area

The safety curtain is equipped with Muting sensors able to effectively discriminate between the person and the material allowed to get through the controlled gate. The essential requirements concerning the Muting function are described in the following Standards:

- ➔ **IEC TS 62046 - "Application of protection devices for people detection".**
- ➔ **EN 415-4 - "Safety on packaging machines – Palletizers and Unpalletizers".**
- ➔ **IEC 61496-1 - "Electro-sensitive protective devices".**

General requirements about safety:

- The Muting function is a temporary suspension of the safety function that needs to be activated and deactivated automatically.
- The activation and subsequent deactivation of the Muting function must take place only through the use of two or more wired and independent signals activated by a correct timing or spatial sequence. This means that a stand-alone failure cannot activate the Muting function.
- It should not be possible to activate the Muting function when SAFEGATE has deactivated the safety outputs.
- It should not be possible to start a Muting function by switching off and then restarting the device.
- Muting must be activated at an appropriate point of the machine cycle, i.e. only when there are no risks for the operator.
- Muting sensors must be mechanically protected so that any impact does not modify their alignment.
- If the distance between the muting sensors is lower than required, the SAFEGATE safety function is not guaranteed.
- Make sure that the MUTING/OVERRIDE signal lamp is correctly installed in a visible location by the operator.

A) 2 INTEGRATED CROSS MUTING SENSORS, ONLY FOR PALLET OUTPUTS (LX)

In this way sensors 1 and 2 are on the same side as the vertical curtain and are placed in front of the dangerous gate. This mode is unidirectional and is useful for protecting gates with pallet output.

The activation of the Muting function occurs after the simultaneous interruption (within 4 sec maximum) of S1 and S2 sensors. As long as both sensors remain busy, the Muting function continues. When the first of the 2 sensors is released, the material will still have 4 seconds to leave the protected area limited by the curtain. The Muting condition will be disabled as soon as the protected area is released.

At the end of 4 seconds, if the curtain is still busy, the OSSD outputs are disabled by interrupting the operation of the machine. This allows selecting the maximum duration of the Muting condition (timeout) as 30 seconds or 9 hours.

→ *Other timings are available with programmable programs.*

⚠ *For the safe operation of the LX configuration, it is absolutely essential that the horizontal Muting sensor elements are located within the hazardous area.*

⚠ *The minimum distance between two consecutive pallets must be less than 10 cm or greater than 32cm.*

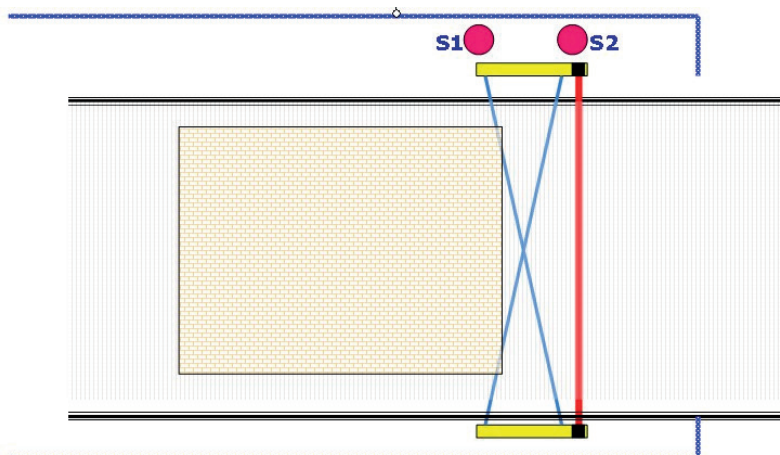
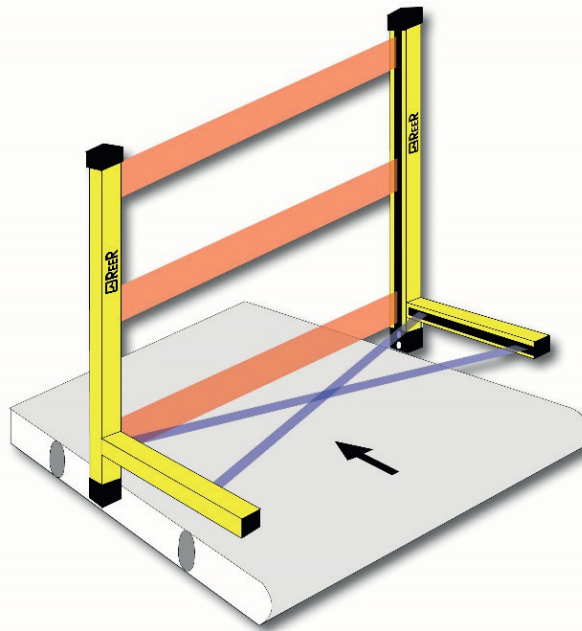

B) 2 INTEGRATED PARALLEL MUTING SENSORS, ONLY FOR PALLET OUTPUTS (L2)

In this way sensors 1 and 2 are on the same side as the vertical curtain and are placed in front of the dangerous gate. This mode is unidirectional and is useful for protecting gates with pallet output.

The activation of the Muting function occurs after the simultaneous interruption (within max 4 sec) of sensors S1 and S2. As long as both sensors remain busy, the Muting function continues. When the first of the 2 sensors is released, the material will still have 4 seconds to leave the protected area limited by the curtain. The Muting condition will be disabled as soon as the protected area is released. At the end of 4 seconds, if the curtain is still busy, the OSSD outputs are disabled by interrupting the operation of the machine.

This allows selecting the maximum duration of the Muting condition (timeout) as 30 seconds or 9 hours.

→ *Other timings are available with programmable programs.*

⚠ *For the safe operation of the L2 configuration, it is imperative that horizontal Muting sensors are located within the hazardous area.*

⚠ *The minimum distance between two consecutive pallets must be greater than 40 cm.*

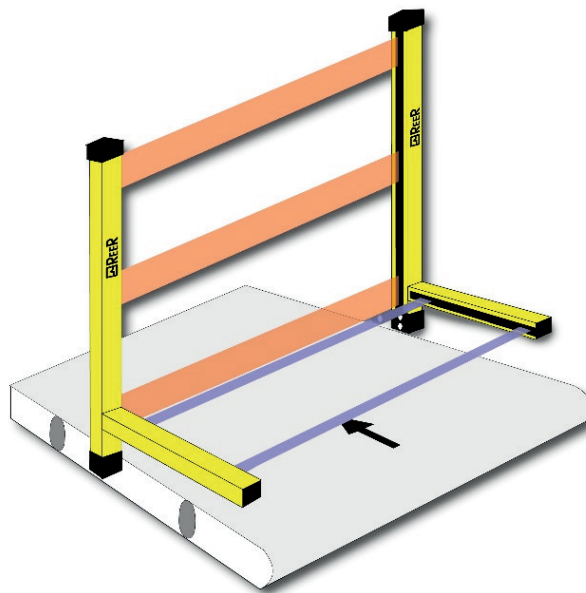

C) 2 INTEGRATED CROSS MUTING SENSORS, FOR BI-DIRECTIONAL GATES (TX)

In this way, the two Muting sensors are each first on a different side of the vertical curtain. This mode is unidirectional and is useful for protecting gates with pallet output.

→ *The crossing point of the two Muting sensors must be placed inside the hazardous area to avoid undesirable and dangerous activations of the Muting function.*

The activation of the Muting function occurs after the simultaneous interruption (within max 4 sec) of sensors S1 and S2. As long as both sensors remain busy, the Muting function continues. By releasing the first of the two sensors, the Muting function is disabled.

This mode also allows selecting the maximum duration of the Muting condition (timeout) as 30 seconds or 9 hours.

→ *Other timings are available with programmable programs.*

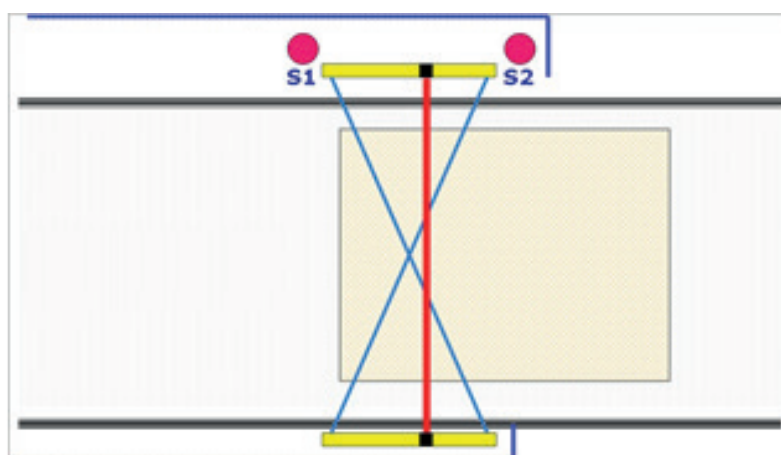
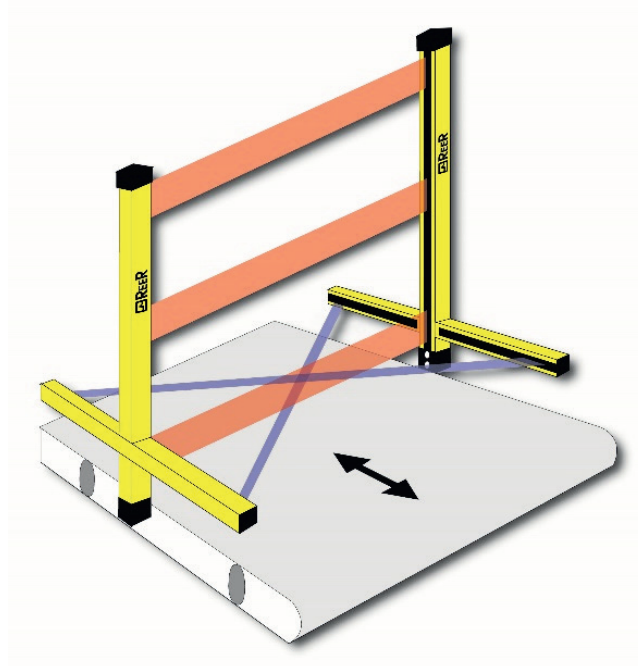

D) 4 INTEGRATED PARALLEL MUTING SENSORS, FOR BI-DIRECTIONAL GATES (T4)

This mode is bidirectional and is useful for protecting gates with pallet output. Using this mode, two different modes of operation are outlined:

Concurrent

The activation of the Muting function occurs after the sensors S1 and S2 are interrupted (within max 4sec) (or S4 and S3 with material moving in the opposite direction).

The Muting state ends after the release of the gate, and of the S3 sensor (or S2 with material moving in the opposite direction).

➔ *For the T4 models (concurrent operation), there are two available timeouts: 1) 30 sec; 2) 9 hours.*

Sequential

The activation of the Muting function occurs after the sequential interruption of sensors S1 and S2 (or S4 and S3 with material moving in the opposite direction) without time limitations.

The Muting state ends after the release of the gate, and of the S3 sensor (or S2 with material moving in the opposite direction).

➔ *For the T4 models (sequential operation), there are two available timeouts: 1) 30 sec; 2) infinite.*

➔ *Other timings are available with programmable programs.*

➔ *In both modes of operation, the minimum pallet length must be 70 cm (to ensure simultaneous occupancy of all four sensors).*

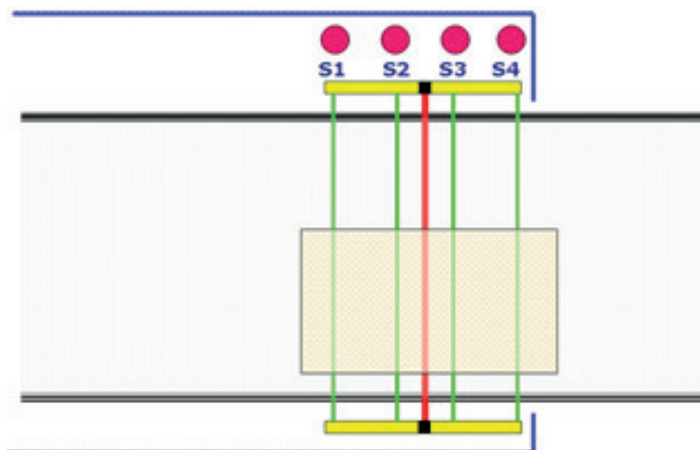
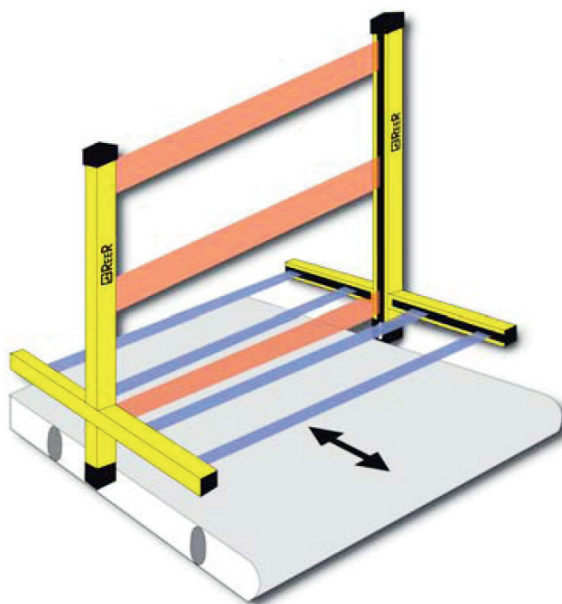

E) 2 EXTERNAL CROSS INTEGRATED MUTING SENSORS, FOR BI-DIRECTIONAL GATES (TX).

This mode is bidirectional and is useful for protecting gates with pallet output.

→ *The crossing point of the two Muting sensors must be placed inside the hazardous area to avoid undesirable and dangerous activations of the Muting function.*

The activation of the Muting function occurs after the simultaneous interruption (within max 4 sec) of sensors S1 and S2. As long as both sensors remain busy, the Muting function continues. When the first of the two sensors is released, the Muting function is disabled. In this mode of operation the maximum duration of the Muting condition (timeout) can be selected in 30 seconds or 9 hours.

→ *Other timings are available with programmable programs.*

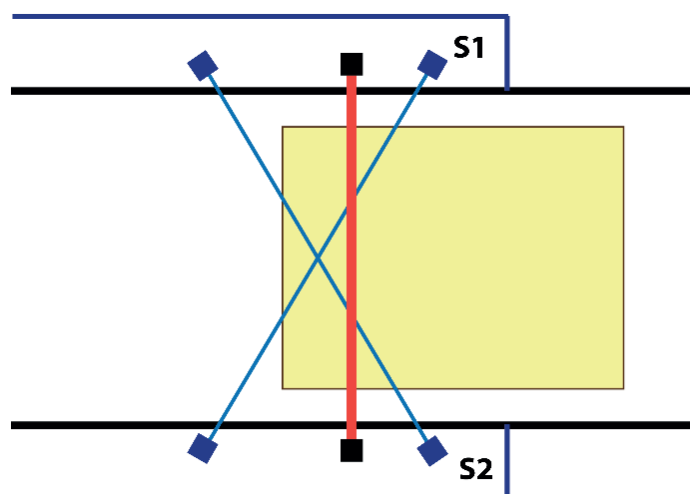
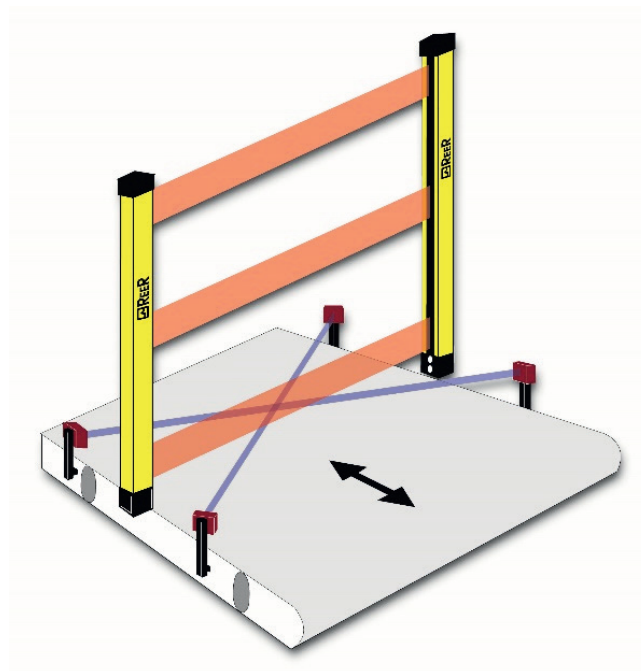

F) 4 EXTERNAL PARALLEL MUTING SENSORS, FOR BI-DIRECTIONAL GATES (T4).

This mode is bidirectional and is useful for protecting gates with pallet output. Using this mode, two different modes of operation are outlined:

Concurrent

The activation of the Muting function occurs after the sensors S1 and S2 are interrupted (within max 4 sec) (or S4 and S3 with material moving in the opposite direction).

The Muting state ends after the release of the gate, and of the S3 sensor (or S2 with material moving in the opposite direction).

➔ **For the T4 models (concurrent operation), there are two available timeouts: 1) 30 sec; 2) 9 hours.**

Sequential

The activation of the Muting function occurs after the sequential interruption of sensors S1 and S2 (or S4 and S3 with material moving in the opposite direction).

The Muting state ends after the release of the gate, and of the S3 sensor (or S2 with material moving in the opposite direction).

➔ **For the T4 models (sequential operation), there are two available timeouts: 1) 30 sec; 2) infinite.**

➔ **Other timings are available with programmable programs.**

➔ **In both modes of operation, the minimum pallet length must be 70 cm (to ensure simultaneous occupancy of all four sensors).**

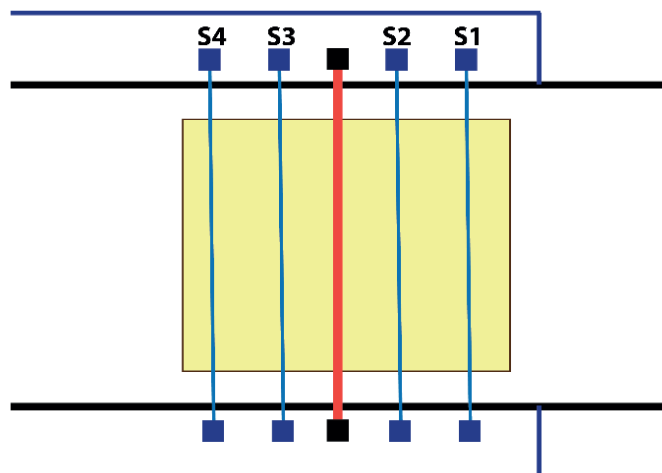
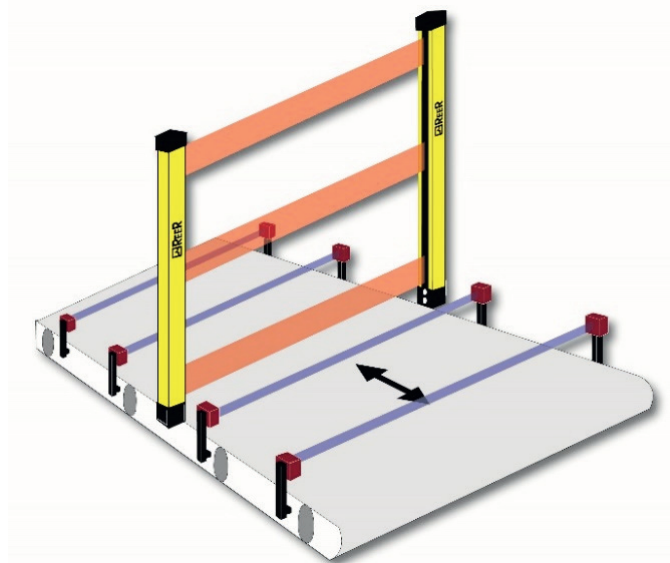

PARTIAL MUTING

The Partial Muting feature allows you to limit the Muting function to a number of well-defined beams. By this function, you can enable the Muting function only for those beams that will be interrupted by the passage of the material (e.g. lower pallets at the end of the product cycle). The remaining beams, however, can be kept active to protect the dangerous gate.

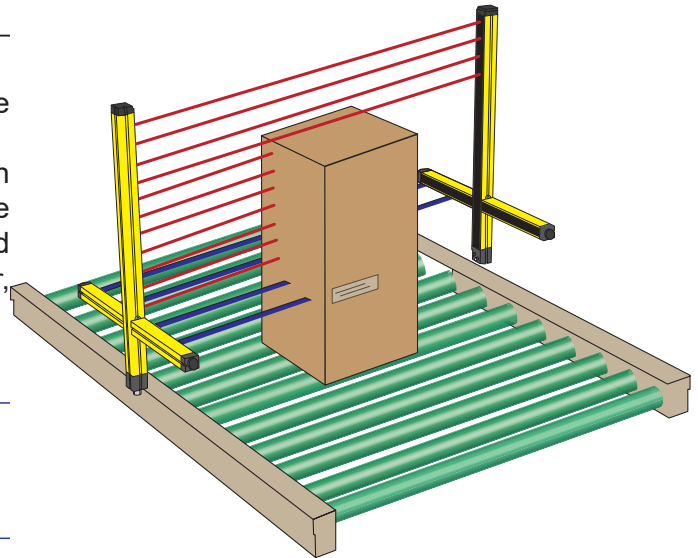

→ ***This function is only available on SMP/SMPO models (except 2B) and must be managed through the Safegate Configurator software (select “Partial Muting Enabling”).***

The software should then select the number of beams affected by Partial Muting, taking into account that the first Partial Muting beam always starts from the bottom (connectors side).

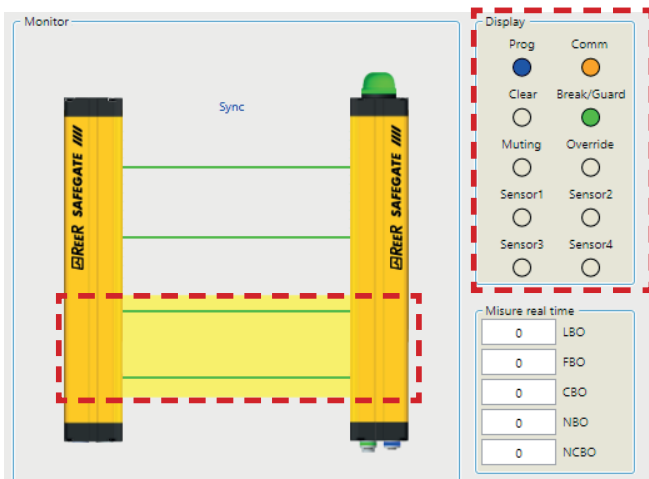

For this operation, it may be useful to verify the Monitor software function (free beams are indicated by different colouring than the busy ones) and the various numerical information on the side (LBO, FBO, etc.).

Only one value can be entered when programming the number of beams affected by this function. There are two types of partial Muting and, for both, the “Partial Muting” input pin (pin 6 of M12 12-pin connector on the active element) must be used.

Partial Muting with Enable

With this option, the Partial Muting function is normally deactivated. To activate this function, the input signal (pin 6 of the active element) must switch from LO to HI (rising edge) before starting the Muting cycle.

Partial Muting with Disable



With this option the Partial Muting function is normally active. To activate this function, the input signal (pin 6 of the active element) must switch from LO to HI (rising edge) before starting the Muting cycle.

→ ***Refer to the “OPERATING MODES” section to correctly set this function.***

MUTING OVERRIDE

The OVERRIDE function becomes necessary when, after incorrect Muting activation sequences, the machine stops leaving the material in the dangerous gate.

In this situation, the OSSD outputs are inactive because the curtain and/or at least one Muting sensor are busy. In this condition, the OVERRIDE request LED flashes.

-  ***This operation activates the OSSD outputs to remove the material obstructing the gate.***
-  ***During the entire phase in which the OVERRIDE function is active, the Override/Muting lamp flashes. Periodically verify the efficiency of this lamp (during Muting or Override phases).***
-  ***The Pulse Override command automatically activates the curtain outputs until both the curtain and the Muting sensors are again free of obstacles. During this period the curtain is not able to protect access to the dangerous gate. It is therefore necessary that all operations be conducted under close supervision of experienced personnel.***

The user will use the type of Override previously configured:

1. Override with Hold-to-run-Control
2. Override with Pulse Control

Override with Hold-to-run-Control

Activation of this function must be done by bringing both active element pins 9 and 10 to + 24VDC (within a 400ms time window), for example by using a 2-way key switch with spring return.

Override has a maximum duration of 15 minutes; it can end due to two different conditions.

1. When the selector is released or the 15 minutes expire, the override ends, bringing the outputs to OFF, turning off the lamp, and returning the display to normal. However, it is still possible to start a new override, releasing the selector and reactivating it.
2. At the release of the curtain and sensors (clear gate) the override ends and the GUARD condition is reactivated (the curtain is working properly) without additional commands.

Override with Pulse Control

The activation of this function must occur inverting (within a time window of 400 ms) the condition of pins 9 and 10 of the active element (e.g. through the use of a 2-way switch).

MAXIMUM OVERRIDE TIME (MODELS WITH HARDWARE CONFIGURATION)

The override has a maximum duration of 15 minutes (repeatable).

The function can only restart with a new request complying with the following conditions:

1. Maximum OVERRIDE time (after n consecutive requests) = 60 min
2. Maximum number of consecutive OVERRIDE requests = 30.

MAXIMUM OVERRIDE TIME (MODELS WITH SOFTWARE CONFIGURATION)

The function can only restart with a new request complying with the following conditions:

1. Maximum OVERRIDE time (after n consecutive requests) = **4 x timeout override'**
2. Maximum number of consecutive OVERRIDE requests = 30.

At the release of the curtain and sensors (clear gate) the override ends and the GUARD condition is reactivated (the curtain is working properly) without additional commands.

The timer (point 1) and the counter (point 2) are reset if one of the following conditions occurs:

1. A proper sequence of Muting.
2. A system reset (turning it off and on).

¹ the parameter "timeout override" can be set through the configuration software.

INSTALLATION

CALCULATION OF THE SAFETY DISTANCE

The effectiveness of the protection heavily depends on the correct positioning of the curtain according to the danger. The curtain must be positioned at a distance greater than or equal to the minimum safety distance S so that reaching the dangerous point can only be achieved after the dangerous operation of the machine has stopped.

The positioning shall be such that:

- Reaching the dangerous point is avoided without crossing the area controlled by the curtain.
- No person is allowed in the dangerous area without this being detected. For this case, additional safety devices (e.g. horizontal light curtains) may be required.

The ISO 13855 standard provides the elements for calculating the safety distance.

If the machine under consideration is subject to a type C specific standard, reference should be made to this rule.

If the S distance calculated appears to be excessive, it is necessary:

- to reduce the total time the machine is off
- to improve the resolution of the curtain.

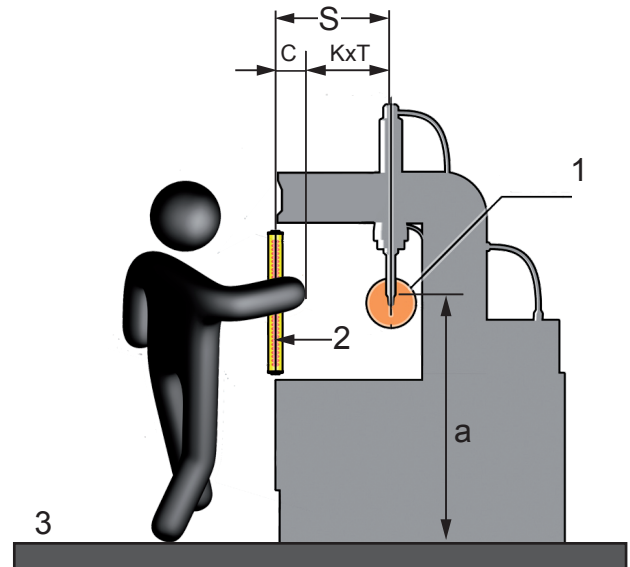

1. Dangerous point
2. Protected plane
3. Reference plane
- a. Height of dangerous point
- S. Safety distance

GENERAL FORMULA FOR CALCULATING THE SAFETY DISTANCE

$$S = K \times T + C$$

S	minimum safety distance between the protection and the dangerous point, expressed in mm.
K	advance speed of the body or parts of the body, expressed in mm per second. K values can be: K = 2000 mm per second for safety distances up to 500 mm K = 1600 mm per second for safety distances over 500 mm
T	Total machine stopping time including: T1 response time of the protection device in seconds T2 machine reaction time to stop the hazardous operation, in seconds.
C	additional distance expressed in mm.

MODELS WITH 2/3/4 beams

Body detection curtains.
Curtain with 2/3/4 beams

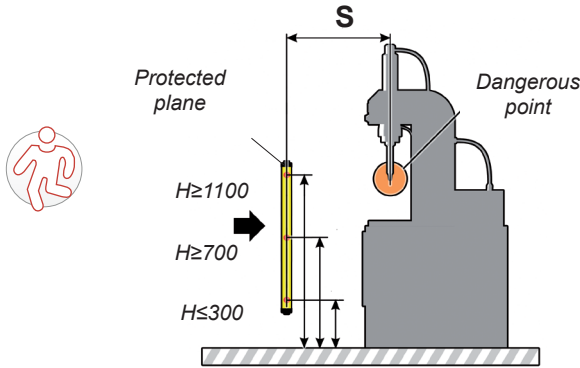

Refer to the general formula for the safety distance calculation.

$$S = K \times T + C$$

$$S = 1600 \times T + 850$$

Recommended height according to the number of beams

N°	Recommended height
2	400 - 900 mm
3	300 - 700 - 1100 mm
4	300 - 600 - 900 - 1200 mm

- ➔ The S distance must not be less than 100 mm
- ➔ If the resulting distance S is greater than 500 mm, it is possible to recalculate the distance using $K = 1600$ but in this case the distance must still not be less than 500 mm
- ⚡ If the distance between the muting sensors is lower than required, the SAFEGATE safety function is not guaranteed.
- ➔ For applications on packaging machines (palletizers and un palletizers), follow the instructions in European standard EN 415-4, which are repeated here.

From low level (floor)
Device with 3 beams at least

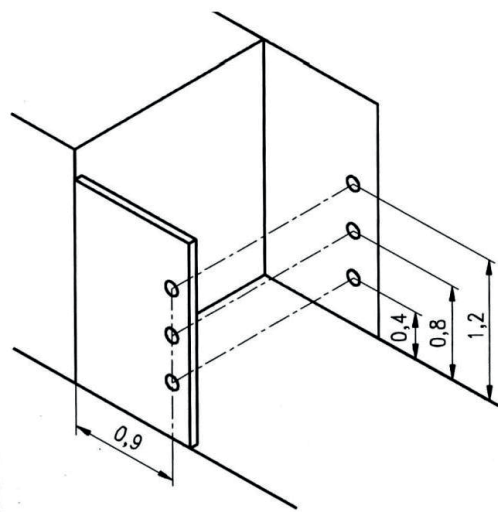

Above the conveyor (rollers)
Device with 2 beams at least

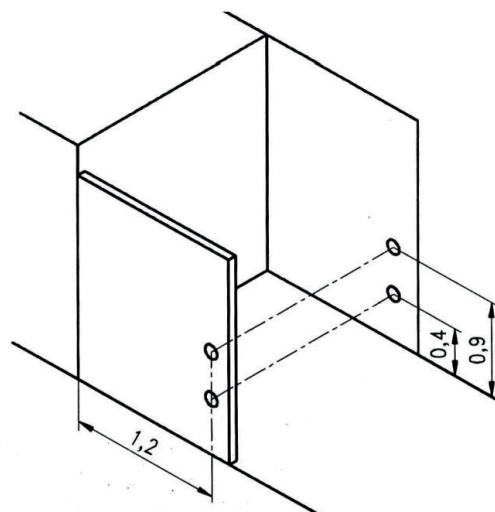

Dimensions in m

MULTIPLE SYSTEMS

➔ *When using multiple SAFEGATE TRX systems, it is necessary to avoid them interfering optically with one another: position the elements so that the beam emitted by the system Active Element is received only by the respective Passive Element.*

The following figure shows some examples of correct positioning between the two photoelectric systems. An incorrect positioning may cause interference, leading to an abnormal operation.

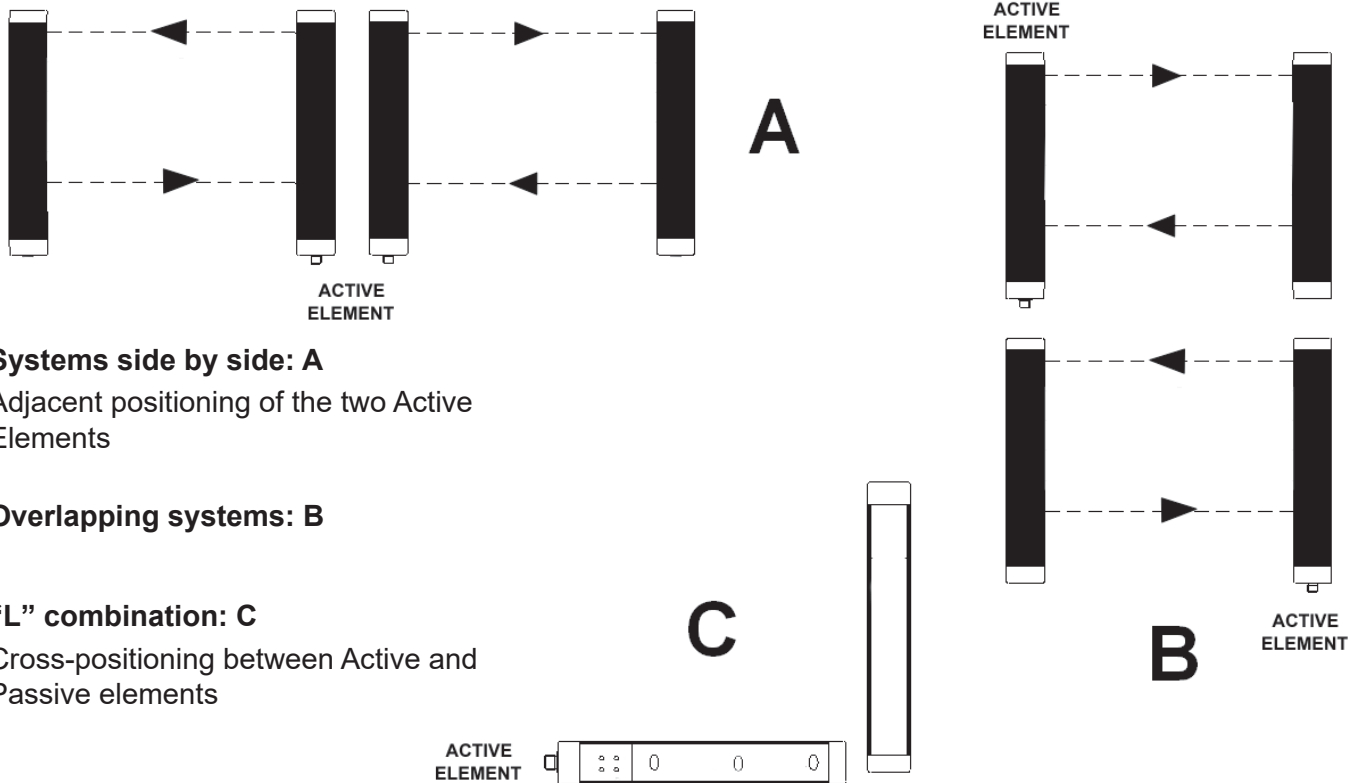

Systems side by side: A

Adjacent positioning of the two Active Elements

Overlapping systems: B

'L' combination: C

Cross-positioning between Active and Passive elements

DISTANCE FROM REFLECTING SURFACES

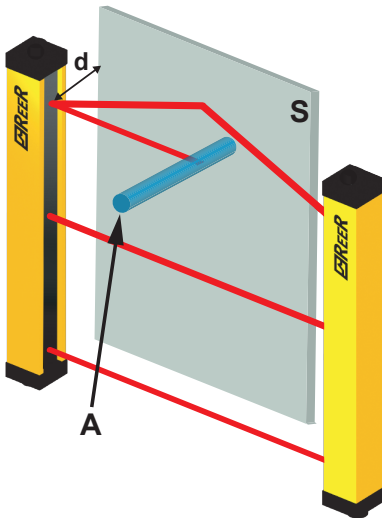

⚠ The presence of reflective surfaces located near the light curtain can cause spurious reflections preventing the detection. Referring to the following Figure object “A” is not detected due to the plane “S” reflecting the beam and thus closing the optical path between the Active and Passive elements. It is therefore necessary to keep a minimum distance “d” between any reflecting surfaces and the protected area.

⚠ For calculating the minimum distance d, it is recommended to use the values set for Type 4 devices according to IEC/EN 61496-2.

The following figure shows the above-mentioned values of the distance d based on the distance between the Active Element and the Passive Element.

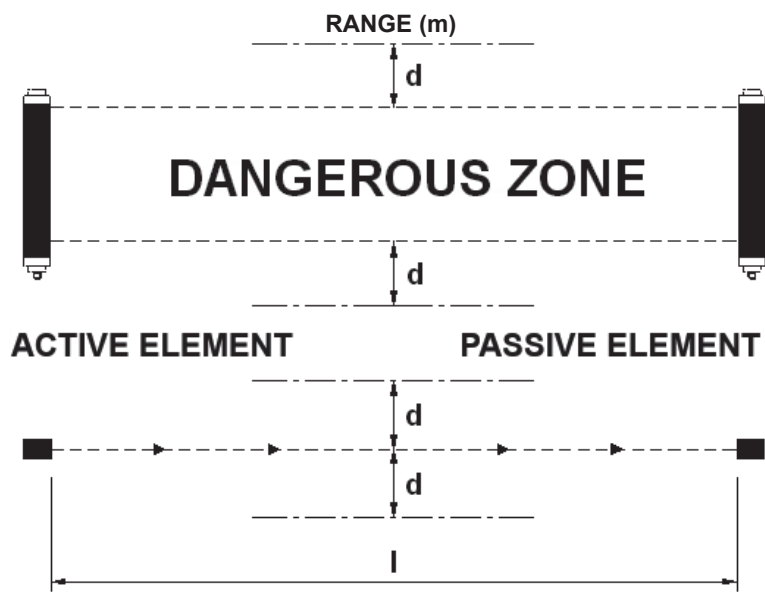
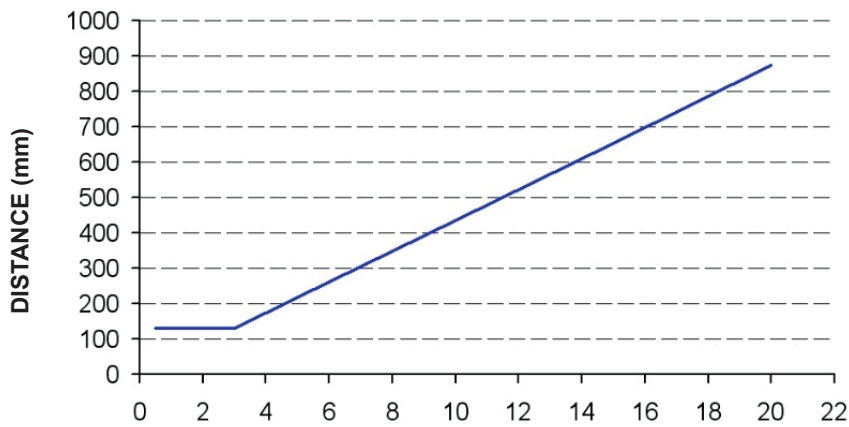

➔ Once the system is installed, verify any reflective surfaces which may intercept the beams, first in the centre and then near the Active Element and Passive Element. During this procedure, the red LED on the Passive Element must never go off.

MECHANICAL ASSEMBLY AND OPTICAL ALIGNMENT

The following operations must only be carried out by qualified personnel, otherwise you may lose the machine safety function.

- The Active and Passive elements must be mounted one in front of the other at a distance equal to or less than that indicated in the technical data; using the supplied inserts and brackets, position the Active and Passive elements so that they are aligned and parallel to each other and with the connectors facing the same side.

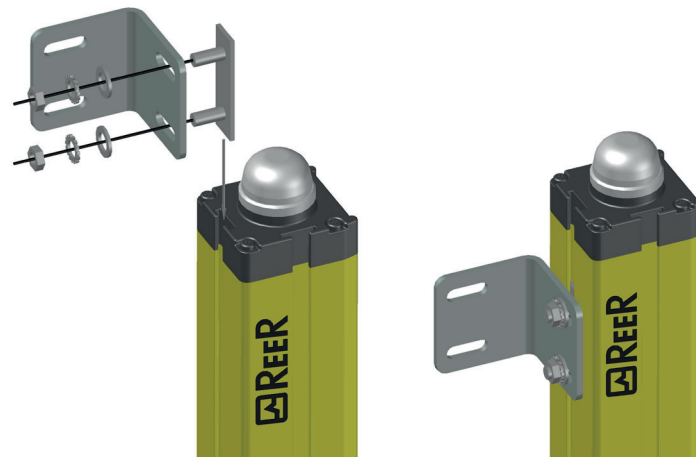

- The perfect alignment between Active and Passive Elements is essential for the smooth operation of the curtain; this operation is facilitated by observing the Active element signalling LEDs.
- Make electrical connections according to the directions of the dedicated chapter.

➔ **Pay particular attention to the SAFEGATE model you are connecting. Connections may vary depending on the model.**

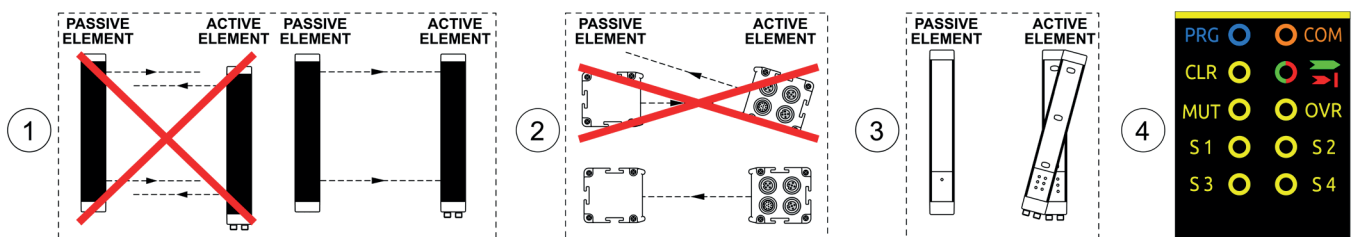



- Place the optical axis of the first and last beams of the Active Element on the same axis as that of the Passive Element.
- Move the Active Element to find the area within which the green LED stays on, then place the first beam (the one near the signal LED) at the centre of this area.
- Using this beam as a pivot, with small lateral displacements of the opposite end, move to the free guarded area condition, which in this situation will be indicated by the green LED on the Passive Element.
- Firmly tighten the Active Element and the Passive Element.

➔ **If the Active and Passive Elements are mounted in areas subject to strong vibrations, in order not to compromise the operation of the circuits, it is necessary to use anti-vibration dampers.**

SM - SMO MODELS ELECTRICAL CONNECTIONS

Before proceeding to the electrical connections make sure that the available power supply voltage is in accordance with the data specified in the technical data.

-  **The Active Element must be powered at a 24Vdc±20% (PELV, in compliance with the standard EN 60204-1 (Chapter 6.4)).**
-  **Make sure the connectors are screwed down tightly to ensure correct barrier operation!**
-  **In order to ensure the declared Environmental Protection Degree (IP65-IP67), it is mandatory to protect the unused connectors with the provided protection caps.**

PRECAUTIONS

- Make the connection to earth before making any other connections.
- Perform all connections before energizing Safegate.
- The ground connection (0VDC) must be common to all system components.

WARNINGS ON CONNECTION CABLES

- ➔ **Conductor Size: 0,25÷2,5 mm².**
- ➔ **It is recommended to keep SAFEGATE's power supply separate from that of other electrical power equipment (electric motors, inverters, frequency changers) or other sources of disturbance.**
- ➔ **For connections more than 20 m long, cables with a section of at least 0.5 mm² must be used (AWG16), (1 mm² for lengths over 50 m).**

ACTIVE ELEMENT CONNECTIONS

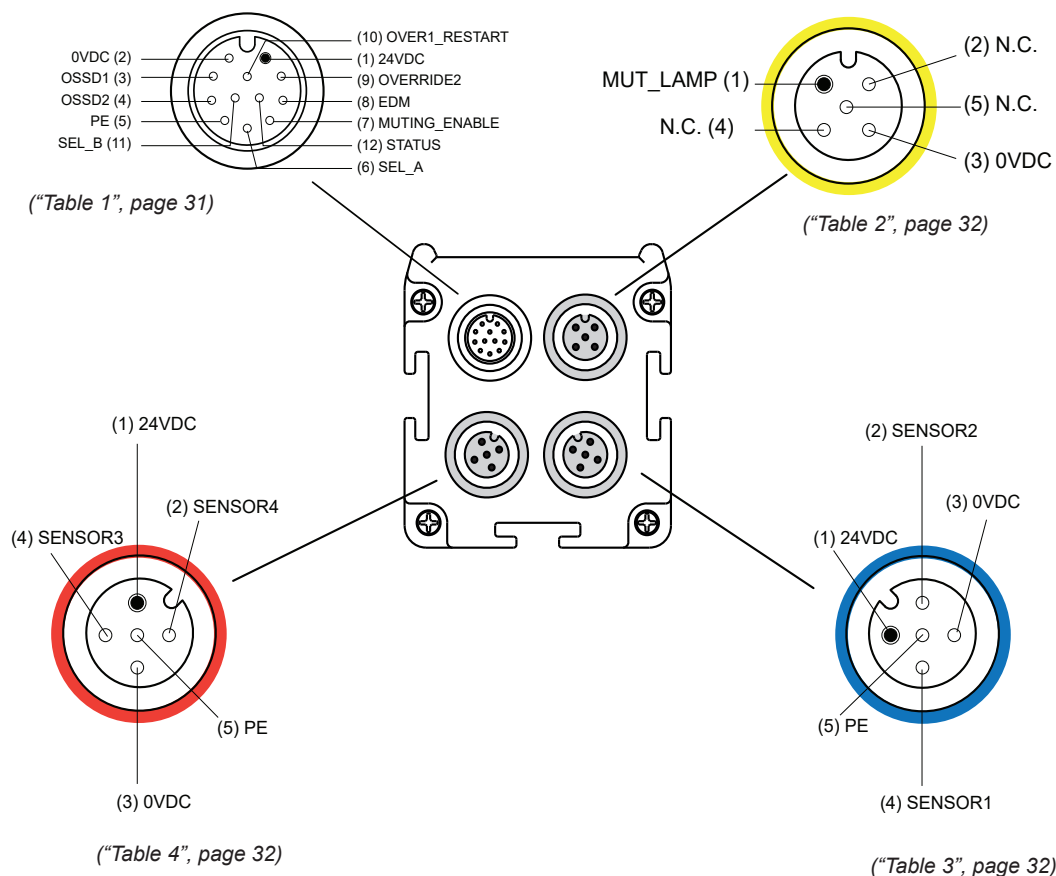

Table 1
MAIN MALE CONNECTOR - M12 - 12 PIN

PIN	COLOUR	SIGNAL	IN/OUT	DESCRIPTION	ELECTRICAL LEVEL
1	Brown	24VDC	-	POWER SUPPLY 24 VDC	-
2	Blue	0VDC	-	POWER SUPPLY 0VDC	-
3	White	OSSD1	Output	STATIC SAFETY OUTPUTS	PNP active high
4	Green	OSSD2	Output		
5	Pink	PE	-	EARTH CONNECTION	-
6	Yellow	SEL_A	Input	MUTING CONFIGURATION	Refer to "SELECTION OF OPERATING MODES" , page 33
7	Black	MUT_ENABLE	Input	EXTERNAL MUTING ENABLE	Safegate considers the muting cycle correct if it detects a "MUTING ENABLE" signal rising edge before the use of the sensors
8	Grey	EDM	Input	FEEDBACK K1/K2	External contactors feedback "EDM" , page 34
9	Red	OVERRIDE2	Input	OVERRIDE REQUEST	Refer to the section "OVERRIDE" , page 35
10	Violet	OVERRIDE1	Input	OVERRIDE REQUEST	Refer to the section "OVERRIDE" , page 35
		RESTART		RESTART INTERLOCK	Refer to the table "RESTART (MANUAL OPERATION)" , page 36
11	Grey/ Pink	SEL_B	Input	MUTING CONFIGURATION	Refer to the section "SELECTION OF OPERATING MODES" , page 33
12	Red/Blue	STATUS	Output	SYSTEM STATUS	PNP active high

➔ **When connecting high inductive loads to OSSDs, use suitable voltage suppressors on the outputs.**
 ⚡ **In free protected area conditions, the Active Element provides a voltage of 24VDC on both outputs. Therefore, the established load must be connected between both output terminals and the 0VDC.**

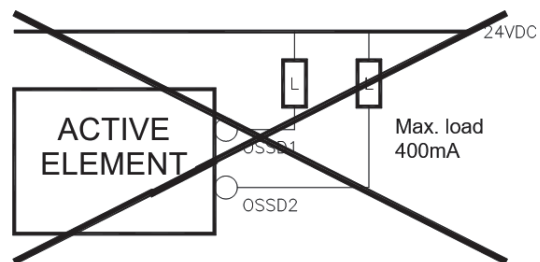
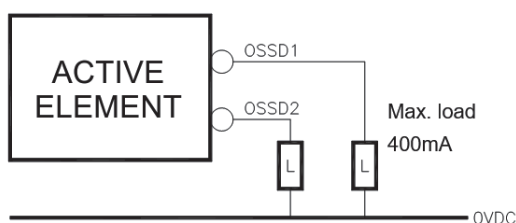

Table 2 MUTING LAMP FEMALE CONNECTOR					
PIN	COLOUR	SIGNAL	IN/OUT	DESCRIPTION	ELECTRICAL LEVEL
1	Brown	MUT_LAMP	Output	Muting Lamp activation command	Active Muting 24VDC
2	White	n.c.	-	-	-
3	Blue	0VDC	-	Muting Lamp 0VDC	0VDC
4	Black	n.c.	-	-	-
5	Grey	n.c.	-	-	-

Table 3 FEMALE CONNECTOR POWER SUPPLY SENSORS MUTING 1 - 2 - M12 - 5-PIN					
PIN	COLOUR	SIGNAL	IN/OUT	DESCRIPTION	ELECTRICAL LEVEL
1	Brown	24VDC	-	Sensor Power Supply 24VDC	Positive
2	White	SENSOR2	Input	SENSOR 2 Status	< 5VDC : CLEAR SENSOR 11÷30 VDC : ACTUATED SENSOR
3	Blue	0VDC	-	Sensor Power Supply 0VDC	Negative
4	Black	SENSOR1	Input	SENSOR 1 Status	< 5VDC : CLEAR SENSOR 11÷30 VDC : ACTUATED SENSOR
5	Grey	PE	-	EARTH CONNECTION	-

Table 4 FEMALE CONNECTOR POWER SUPPLY/SENSORS MUTING 3 - 4 - M12 - 5-PIN					
PIN	COLOUR	SIGNAL	IN/OUT	DESCRIPTION	ELECTRICAL LEVEL
1	Brown	24VDC	-	Sensor Power Supply 24VDC	Positive
2	White	SENSOR4	Input	SENSOR 4 Status	< 5VDC : CLEAR SENSOR 11÷30 VDC : ACTUATED SENSOR
3	Blue	0VDC	-	Sensor Power Supply 0VDC	Negative
4	Black	SENSOR3	Input	SENSOR 3 Status	< 5VDC : CLEAR SENSOR 11÷30 VDC : ACTUATED SENSOR
5	Grey	PE	-	EARTH CONNECTION	-

→ Using LX or TX configuration with 2 sensors: **SENSOR1** wiring is mandatory, while the position of the second muting sensor is free between **SENSOR2** and **SENSOR3**.
SENSOR2: sensor arms MALX; **SENSOR3**: sensor arms MATX or external photocells.

TEST FUNCTION

The SAFEGATE barrier system features an automatic self-diagnosis function that enables it to detect response time malfunctions (this time is declared for each model).

This fault detection system is always active and does not require any external intervention.

SELECTION OF OPERATING MODES

The SAFEGATE Active Element inputs (main male connector - M12 - 12pin) allow the configuration of the various operating modes.

It is therefore necessary, when switching on, to properly connect the SAFEGATE Active Element inputs for proper operation, as shown below.

The following tables allow the user to configure the type of Muting to be adopted in terms of: MUTING MODE, TIMEOUT MUTING, OVERRIDE TYPOLOGY.

 **The incorrect setting of the Muting parameters by the operator compromises the safe operation of the barrier.**

MANUAL MODE	SEL_A (pin 6)	SEL_B (pin 11)	MUTING MODE	MUTING TIMEOUT
	24VDC (1)	OSSD1 (3)	4 SENSORS, SEQUENTIAL	30 s
	24VDC (1)	OSSD2 (4)	4 SENSORS, SEQUENTIAL	∞
	OSSD2 (4)	OSSD1 (3)	2 SENSORS, "TX" MODE	30 s
	OSSD1 (3)	OSSD2 (4)	2 SENSORS, "TX" MODE	9 hours
	OSSD1 (3)	24VDC (1)	2 SENSORS, "L" MODE	30 s
	OSSD2 (4)	24VDC (1)	2 SENSORS, "L" MODE	9 hours
	OSSD2 (4)	OSSD2 (4)	4 SENSORS CONCURRENT	30 s
	OSSD1 (3)	OSSD1 (3)	4 SENSORS CONCURRENT	9 hours
	n.c. / 0VDC	n.c. / 0VDC	Configuration error	
n.c. / 0VDC	n.c. / 0VDC	SPM/SPMO models: programming needed		

AUTOMATIC MODE	SEL_A (pin 6)	SEL_B (pin 11)	MUTING MODE	MUTING TIMEOUT
	24VDC (1)	24VDC (1)	4 SENSORS, SEQUENTIAL	30 s
	STATUS (12)	STATUS (12)	4 SENSORS, SEQUENTIAL	∞
	24VDC (1)	STATUS (12)	2 SENSORS, "TX" MODE	30 s
	STATUS (12)	24VDC (1)	2 SENSORS, "TX" MODE	9 hours
	STATUS (12)	OSSD1 (3)	2 SENSORS, "L" MODE	30 s
	OSSD1 (3)	STATUS (12)	2 SENSORS, "L" MODE	9 hours
	STATUS (12)	OSSD2 (4)	4 SENSORS CONCURRENT	30 s
	OSSD2 (4)	STATUS (12)	4 SENSORS CONCURRENT	9 hours
	n.c. / 0VDC	n.c. / 0VDC	Configuration error	
n.c. / 0VDC	n.c. / 0VDC	SPM/SPMO models: programming needed		

EDM

The EDM function (external K1 / K2 control) can be enabled / disabled via hardware:

Hardware configuration

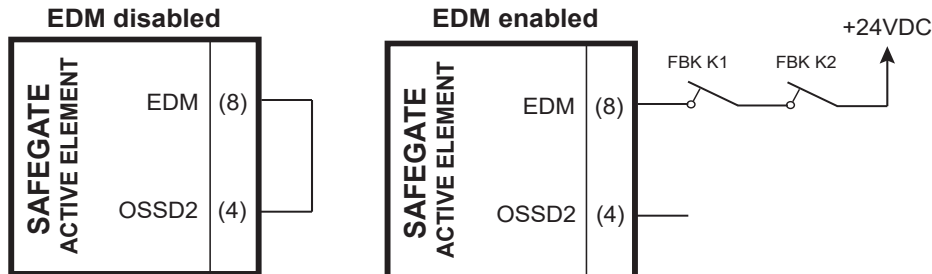

EDM ACTIVATED

SAFEGATE awaits a signal with inverse logic to the condition of the external contactors:

- OSSD1 / OSSD2 ON: External contacts K1/K2 closed: **EDM = OPEN CIRCUIT**
- OSSD1 / OSSD2 OFF: External contacts K1/K2 open: **EDM = CLOSED CIRCUIT**

➔ *The time allowed to elapse from the activation of the OSSD outputs and the opening of the FBK contacts must be $t < 500ms$.*

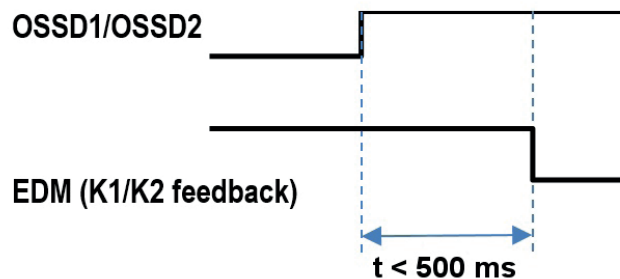

STATUS

The output STATUS is tested for possible 0V or +24VDC blocks.

The test method chosen to perform this check is the "voltage dip test": periodically (every 400ms and for a period of 80µs) the STATUS is switched to 0VDC and its behavior is checked, if the test results are not consistent the barrier is brought to a safe state.

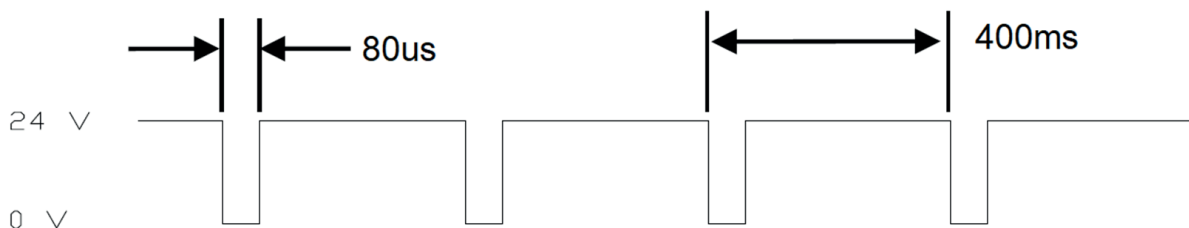

OVERRIDE

SAFEGATE allows you to configure two different types of override; (See paragraph [“MUTING OVERRIDE”](#), page 23 for the description of the following function).

→ *The **OVERRIDE** activation condition for the “L” Muting type requires only the light curtain occupation, while for the “T” Muting type the occupation of light curtain and at least one sensor is required.*

OVERRIDE1 (pin 10)	OVERRIDE2 (pin 9)	SELEZIONE
0	0	Override with Hold-To-Run Control
0	1	Override with Pulse Control
1	0	Wrong configuration
1	1	

OVERRIDE WITH HOLD-TO-RUN CONTROL

The function starts with the simultaneous activation of the two OVERRIDE inputs according to the following table:

OVERRIDE1 (pin 10)	OVERRIDE2 (Pin 9)
0	0
1	1

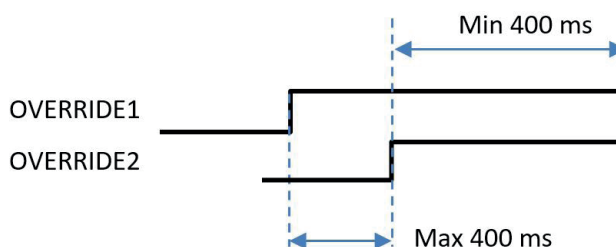

The function starts only if the signals are activated (24VDC) at the same time (within a maximum delay of 400 ms) and the control is kept active for at least 400 ms.

OVERRIDE WITH PULSE CONTROL

The function starts with the simultaneous activation of the two OVERRIDE inputs according to the following table:

OVERRIDE1 (pin 10)	OVERRIDE2 (Pin 9)
0	1
1	0

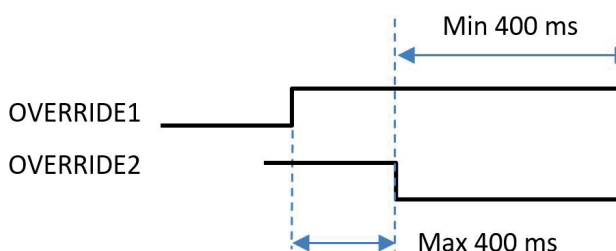

The function starts only if the signals are activated at the same time (within a maximum delay of 400 ms) and the control is kept active for at least 400 ms.

RESTART (MANUAL OPERATION)

➔ Refer to **“APPENDIX A1: SM - SMO MODELS WIRING SAMPLES - MANUAL MODE”**, page 38.

Pin 10 has RESTART function. As a result of occupation of the protected area, OSSDs outputs will be deactivated (OFF) (Manual mode - start/restart interlock enabled).

➔ To reactivate OSSDs press and release the **N.O. RESTART** pushbutton connected to 24VDC. Verify the logical sequence: **0 → 1 → 0**.

➤ The high level (24Vdc) time must be between 100 ms and 5 s.

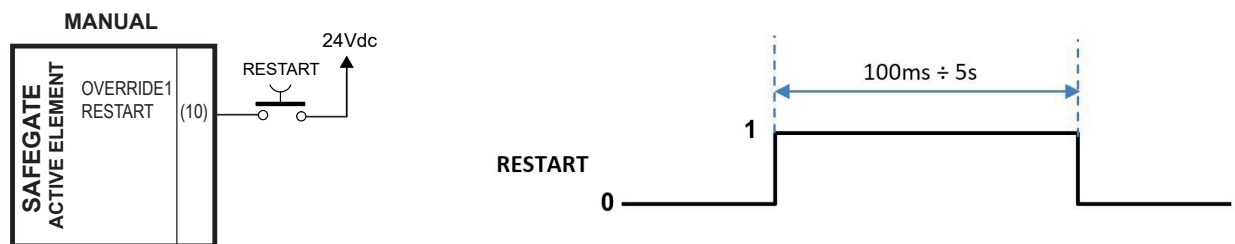

⚠ Use in manual mode (start/restart interlock enabled) is mandatory in case the safety device controls a gate to protect a dangerous area and a person, once crossed the gate, can stay in the hazardous area without being detected (use as a ‘trip device’ according to IEC 61496).

⚠ The Restart command must be located outside the hazardous area, at a point where the hazardous area and the entire working area concerned are clearly visible.

⚠ It must not be possible to reach the command from inside the hazardous area.

AUTOMATIC OPERATION

➔ Refer to **“APPENDIX A2: SM - SMO MODELS WIRING SAMPLES - AUTOMATIC MODE”**, page 40

In Automatic operating mode, the OSSD1 and OSSD2 safety outputs follow the status of the light curtain:

- with guarded area free, the outputs are ON.
- with guarded area occupied, the outputs are OFF.

⚠ If the SAFEGATE light curtain is used in AUTOMATIC mode, it will not be equipped with a start/restart interlock circuit. In most applications, this safety function is mandatory. Carefully evaluate the risks analysis of your own application.

MUTING ENABLE

SAFEGATE can be configured in such a way that the muting cycle only starts after a signal of valid MUTING ENABLE.

Pin 7 (MUTING_ENABLE) and 12 (STATUS) must be connected at power up as indicated:

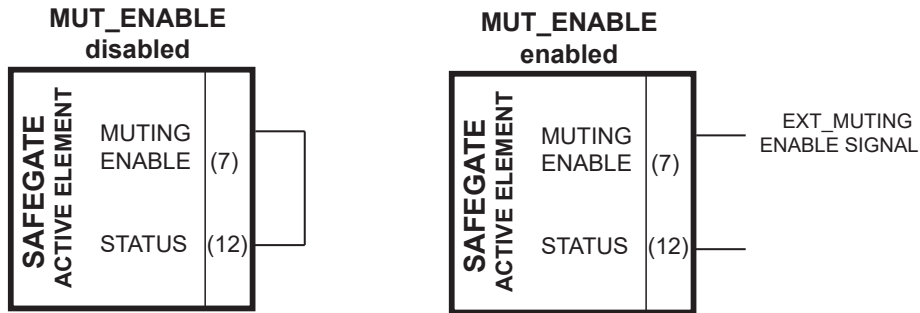

OPERATION	
Disabled	The Muting cycle is activated without considering the MUTING ENABLE signal
Enabled	The Muting cycle is activated only with the correct transition of the MUTING ENABLE signal (see figure below) and will terminate with the release of the last sensor.

Muting Enable active: correct Muting sequence

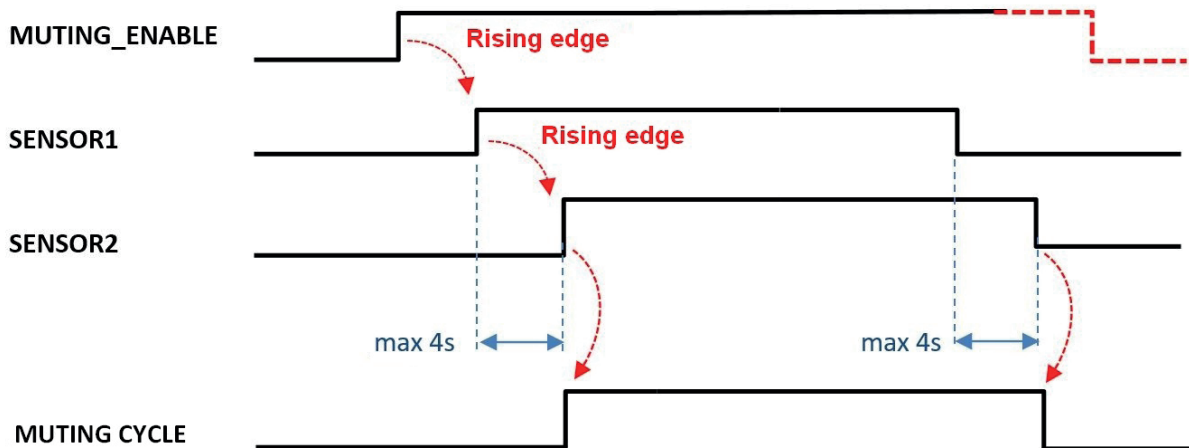

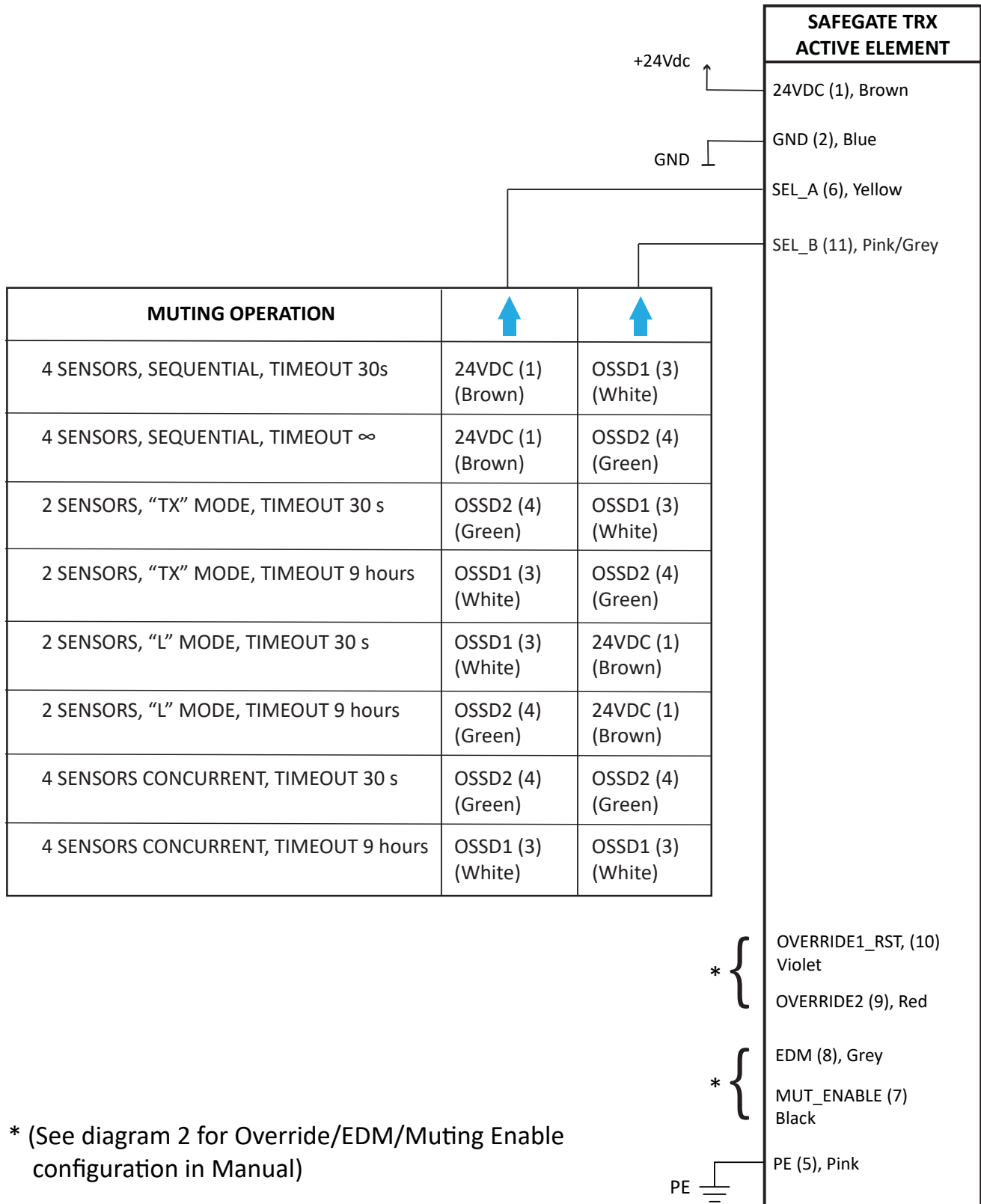
APPENDIX A1: SM - SMO MODELS WIRING SAMPLES - MANUAL MODE
**1 - WIRING CONFIGURATION
MUTING MODES OF OPERATION (MANUAL MODE)**



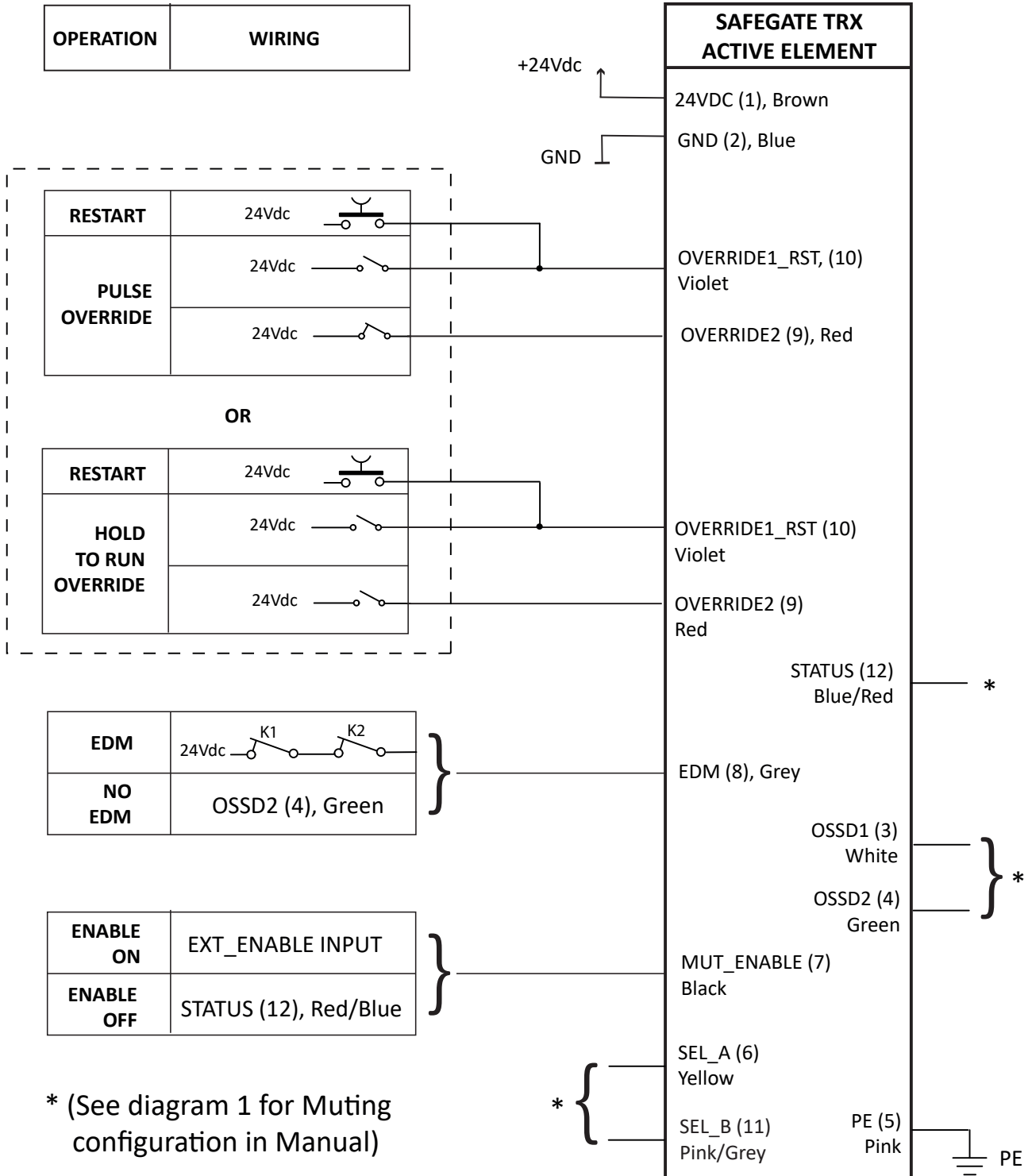

2 - WIRING CONFIGURATION

Override/EDM/Muting Enable (MANUAL MODE)



SMP - SMPO MODELS ELECTRICAL CONNECTIONS



Before proceeding to the electrical connections make sure that the available power supply voltage is in accordance with the data specified in the technical data.

-  **The Active Element must be powered at a 24Vdc±20% (PELV, in compliance with the standard EN 60204-1 (Chapter 6.4)).**
-  **Make sure the connectors are screwed down tightly to ensure correct barrier operation!**
-  **In order to ensure the declared Environmental Protection Degree (IP65-IP67), it is mandatory to protect the unused connectors with the provided protection caps.**

PRECAUTIONS

- Make the connection to earth before making any other connections.
- Perform all connections before energizing Safegate.
- The ground connection (0VDC) must be common to all system components.



WARNINGS ON CONNECTION CABLES

-  **Conductor Size: 0,25÷2,5 mm².**
-  **It is recommended to keep SAFEGATE's power supply separate from that of other electrical power equipment (electric motors, inverters, frequency changers) or other sources of disturbance.**
-  **For connections more than 20 m long, cables with a section of at least 0.5 mm² must be used (AWG16), (1 mm² for lengths over 50 m).**



ACTIVE ELEMENT CONNECTIONS

Available configurations.

1. Configurations with hardware wiring:

-  **If the operator wishes to configure SMP/SMPO models using a hardware wiring, it is necessary to refer to the diagrams in paragraphs [“APPENDIX A1: SM - SMO MODELS WIRING SAMPLES - MANUAL MODE”, page 37](#) and [“APPENDIX A2: SM - SMO MODELS WIRING SAMPLES - AUTOMATIC MODE”, page 42](#). The SAFEGATE Factory Settings do not provide any configuration.**
-  **In case of already programmed Safegate (blue led ON) it is necessary to reset the existing configuration, using the “Safegate Configurator”; use the command “DELETE CONFIGURATION” (please refer to section [“SOFTWARE SAFEGATE CONFIGURATOR”, page 66](#)) coming back at Factory Setting.**

2. Configurations with “Safegate Configurator” software:

-  **If the operator wishes to configure the SMP/MPO models using the supplied software must connect pin 1 and 2 of the main connector of the Active Element (DO NOT connected all others pin).**
-  **If the operator wishes to switch from hardware to software configuration, must respect at power on the indication of the following table (main connector of the Active Element):**

SEL_A (pin 6)	SEL_B (pin 11)	MUT_ENABLE (pin 7)	EDM (pin 8)
0VDC (or open circuit)	0VDC (or open circuit)	0VDC (or open circuit)	<ul style="list-style-type: none"> • 0VDC, if not requested by the Software. • Connected to 24VDC through FBK K1/K2 of external relays (when requested)

-  **To check the SMP/SMPO model wiring with software configuration, refer to the paragraph [“APPENDIX B: SMP - SMPO MODELS WIRING SAMPLE”, page 50](#) diagrams.**

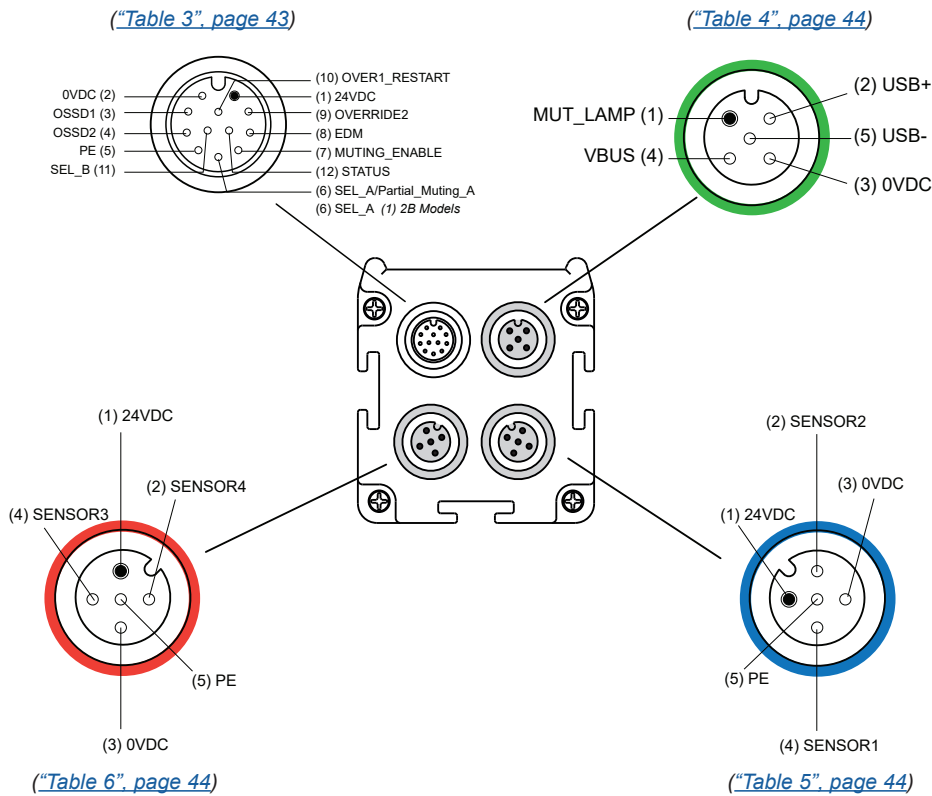

Table 3
MAIN MALE CONNECTOR - M12 - 12 PIN

PIN	COLOUR	SIGNAL	IN/OUT	DESCRIPTION	ELECTRICAL LEVEL
1	Brown	24VDC	-	POWER SUPPLY 24 VDC	-
2	Blue	0VDC	-	POWER SUPPLY 0VDC	-
3	White	OSSD1	Output	STATIC SAFETY OUTPUTS	PNP active high
4	Green	OSSD2	Output		
5	Pink	PE	-	EARTH CONNECTION	-
6	Yellow	SEL_A	Input	MUTING CONFIGURATION	Refer to " SOFTWARE CONFIGURATION: ", page 45
		PARTIAL_MUTING_A⁽²⁾		CONTROL PARTIAL MUTING	The level of the " PARTIAL MUTING ", page 49 is decided through the configuration software
7	Black	MUT_ENABLE	Input	EXTERNAL MUTING ENABLE	Safegate considers the muting cycle correct if it detects a " MUTING ENABLE ", page 48 signal rising edge before the use of the sensors
8	Grey	EDM	Input	FEEDBACK K1/K2	External contactors feedback " EDM ", page 45
9	Red	OVERRIDE2	Input	OVERRIDE REQUEST	Refer to the section " OVERRIDE (pc programming) ", page 46
10	Violet	OVERRIDE1	Input	OVERRIDE REQUEST	Refer to the section " OVERRIDE (pc programming) ", page 46
		RESTART		RESTART INTERLOCK	Refer to the tsection " RESTART (MANUAL OPERATION) ", page 47
11	Grey/ Pink	SEL_B	Input	MUTING CONFIGURATION	Refer to the section " APPENDIX B: SMP - SMPO MODELS WIRING SAMPLE ", page 50
12	Red/Blue	STATUS	Output	AUXILIARY OUTPUT	Refer to the section " SETTING CURTAIN GENERAL PARAMETERS ", page 76

➔ **(1)(2) Partial Muting A is not available for 2B Models.**

➔ When connecting high inductive loads to OSSDs, use suitable voltage suppressors on the outputs.

⚡ In free protected area conditions, the Active Element provides a voltage of 24VDC on both outputs. Therefore, the established load must be connected between both output terminals and the 0VDC.

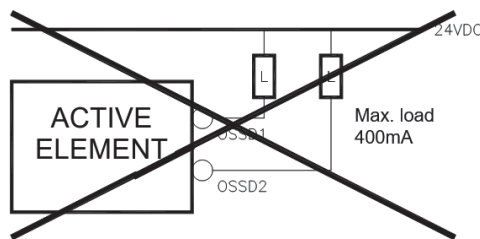
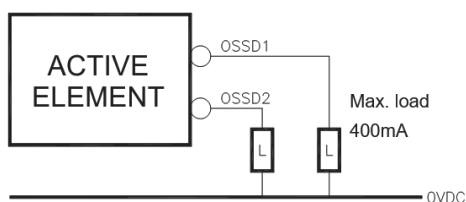

Table 4
MUTING LAMP FEMALE CONNECTOR, CURTAIN PROGRAMMING

PIN	COLOUR	MODEL	IN/OUT	DESCRIPTION	ELECTRICAL LEVEL
1	Brown	MUT_LAMP	Output	Muting Lamp activation command	Active Muting 24VDC
2	White	USB+	In/Out	USB data	-
3	Blue	0VDC	-	Muting Lamp 0VDC	0VDC
4	Black	VBUS	Input	USB Power supply	5VDC
5	Grey	USB-	In/Out	USB data	-

Table 5
FEMALE CONNECTOR POWER SUPPLY SENSORS MUTING 1 - 2 - M12 - 5-PIN

PIN	COLOUR	SIGNAL	IN/OUT	DESCRIPTION	ELECTRICAL LEVEL
1	Brown	24VDC	-	Sensor Power Supply 24VDC	Positive
2	White	SENSOR2	Input	SENSOR 2 Status	< 5VDC : CLEAR SENSOR 11÷30 VDC : ACTUATED SENSOR
3	Blue	0VDC	-	Sensor Power Supply 0VDC	Negative
4	Black	SENSOR1	Input	SENSOR 1 Status	< 5VDC : CLEAR SENSOR 11÷30 VDC : ACTUATED SENSOR
5	Grey	PE	-	EARTH CONNECTION	-

Table 6
FEMALE CONNECTOR POWER SUPPLY/SENSORS MUTING 3 - 4 - M12 - 5-PIN

PIN	COLOUR	SIGNAL	IN/OUT	DESCRIPTION	ELECTRICAL LEVEL
1	Brown	24VDC	-	Sensor Power Supply 24VDC	Positive
2	White	SENSOR4	Input	SENSOR 4 Status	< 5VDC : CLEAR SENSOR 11÷30 VDC : ACTUATED SENSOR
3	Blue	0VDC	-	Sensor Power Supply 0VDC	Negative
4	Black	SENSOR3	Input	SENSOR 3 Status	< 5VDC : CLEAR SENSOR 11÷30 VDC : ACTUATED SENSOR
5	Grey	PE	-	EARTH CONNECTION	-

➔ Using LX or TX configuration with 2 sensors: **SENSOR1** wiring is mandatory, while the position of the second muting sensor is free between **SENSOR2** and **SENSOR3**.
SENSOR2: sensor arms MALX; **SENSOR3**: sensor arms MATX or external photocells.

TEST FUNCTION

The SAFEGATE barrier system features an automatic self-diagnosis function that enables it to detect response time malfunctions (this time is declared for each model).

This fault detection system is always active and does not require any external intervention.

SELECTION OF OPERATING MODES

➔ Configuration of the various modes of operation of the SMP/SMPO models is achieved thanks to the SAFEGATE CONFIGURATOR software.

⚠ The incorrect setting of the Muting parameters by the operator compromises the safe operation of the barrier.

EDM

The EDM function (external K1 / K2 control) can be enabled / disabled via software:

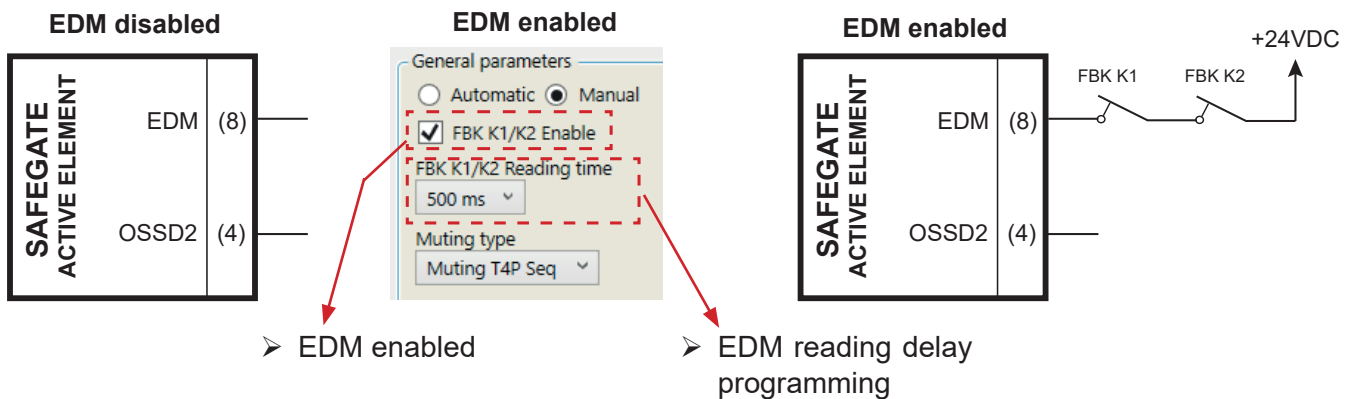

EDM ACTIVATED

SAFEGATE awaits a signal with inverse logic to the condition of the external contactors:

- OSSD1 / OSSD ON: External contacts K1/K2 closed: **EDM = OPEN CIRCUIT**
- OSSD1 / OSSD OFF: External contacts K1/K2 open: **EDM = CLOSED CIRCUIT**

Connect the pin 8 of the main connector to the Active Element as shown above.

The time allowed to elapse from the activation of the OSSD outputs and the opening of the FBK contacts must be the one indicated in the figure below.



STATUS

The output STATUS is tested for possible 0V or +24VDC blocks.

The test method chosen to perform this check is the “voltage dip test”: periodically (every 400ms and for a period of 80µs) the STATUS is switched to 0VDC and its behavior is checked, if the test results are not consistent the barrier is brought to a safe state.

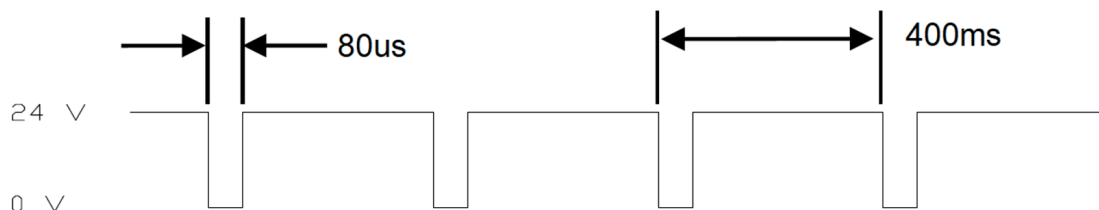

8541205 - rev.7 - 10/07/2023

OVERRIDE (PC PROGRAMMING)

SAFEGATE allows the operator to configure two different types of override; (See paragraph [“MUTING OVERRIDE”](#), page 23 for the description of the following function).

OVERRIDE1 (pin 10)	OVERRIDE2 (pin 9)	SELEZIONE
0	0	Override with Hold-To-Run Control
0	1	Override with Pulse Control

OVERRIDE WITH HOLD-TO-RUN CONTROL

Thanks to the programming software, the operator can choose what kind of OVERRIDE enable (in this case HOLD-TO-RUN CONTROL) and its timeout.

➔ **With occupied sensors: When selected, the activation of at least one sensor is required to activate the OVERRIDE.**

The function starts with the simultaneous activation of the two OVERRIDE inputs according to the following table:

OVERRIDE1 (pin 10)	OVERRIDE2 (Pin 9)
0	0
1	1

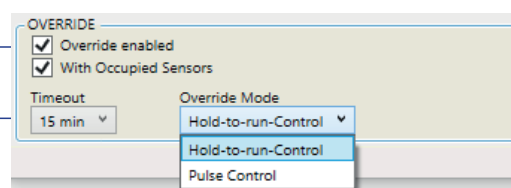
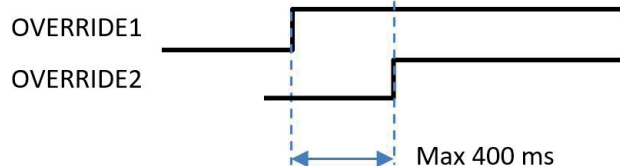

The function only starts if the signals are activated (24VDC) at the same time (within a maximum delay of 400 ms) and the control is maintained active for at least 400 ms.

OVERRIDE WITH PULSE CONTROL

Thanks to the programming software, the operator can choose what kind of OVERRIDE enable (in this case PULSE CONTROL) and its timeout.

➔ **With occupied sensors: When selected, the activation of at least one sensor is required to activate the OVERRIDE.**

The function starts with the simultaneous activation of the two OVERRIDE inputs according to the following table:

OVERRIDE1 (pin 10)	OVERRIDE2 (Pin 9)
0	1
1	0

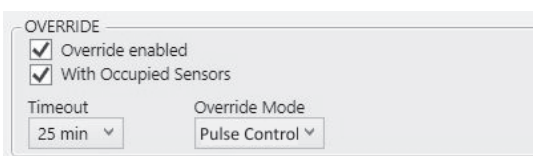
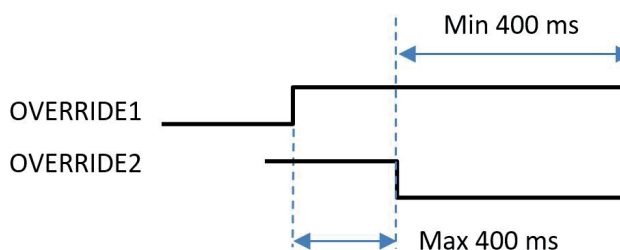

The function starts only if the signals are activated at the same time (within a maximum delay of 400 ms) and the control is maintained active for at least 400 ms.

RESTART (MANUAL OPERATION)

The choice between MANUAL or AUTOMATIC mode of operation is possible thanks to the SAFEGATE CONFIGURATOR software. In Manual mode Pin 10 has RESTART function.

As a result of occupation of the protected area, outputs will be deactivated (start/restart interlock enabled).

➔ **To reactivate OSSDs it needs to press and release the N.O. RESTART pushbutton connected to 24VDC. Verify the logical sequence: 0 → 1 → 0.**

➤ The high level (24Vdc) time must be between 100 ms and 5 s.

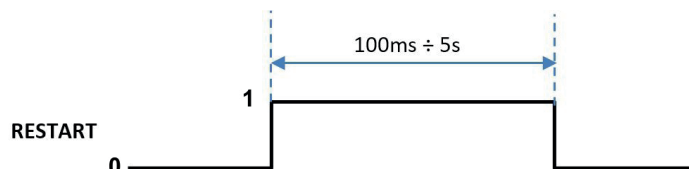
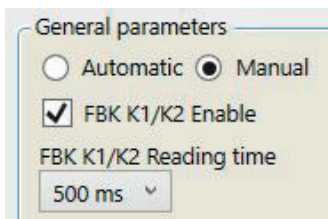

⚠ Use in manual mode (start/restart interlock enabled) is mandatory in case the safety device controls a gate to protect a dangerous area and a person, once crossed the gate, can stay in the hazardous area without being detected (use as a 'trip device' according to IEC 61496).

⚠ The Restart command must be located outside the hazardous area, at a point where the hazardous area and the entire working area concerned are clearly visible.

⚠ It must not be possible to reach the command from inside the hazardous area.

AUTOMATIC OPERATION

The choice between MANUAL or AUTOMATIC mode of operation is achieved thanks to the SAFEGATE CONFIGURATOR software.

In Automatic operating mode, the OSSD1 and OSSD2 safety outputs follow the status of the light curtain:

- with guarded area free, the outputs are ON.
- with guarded area occupied, the outputs are OFF.

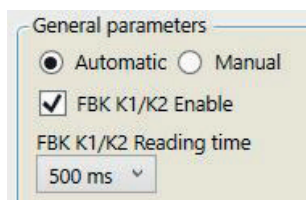

⚠ If the SAFEGATE light curtain is used in AUTOMATIC mode, it will not be equipped with a start/restart interlock circuit. In most applications, this safety function is mandatory. Carefully evaluate the risks analysis of your own application.

MUTING ENABLE

SAFEGATE can be configured in such a way that the muting cycle only starts after a valid MUTING ENABLE signal. Furthermore is possible to choose if the MUTING ENABLE only enables or also disables the Muting function thanks to the programming software.

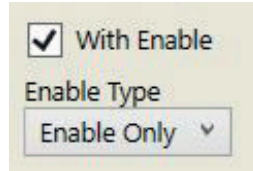

Muting Enable active: correct Muting sequence

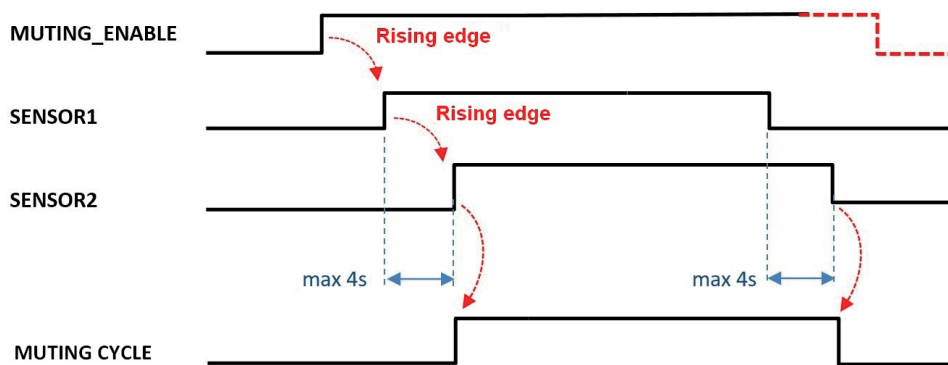

MUTING ENABLE/DISABLE

SAFEGATE can be configured in such a way that the muting cycle only starts after a valid MUTING ENABLE/DISABLE signal. Furthermore is possible to choose if the MUTING ENABLE only enables or also enable/disable the Muting function thanks to the programming software.

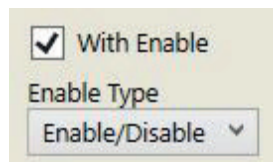

Muting Enable/Disable active: Correct Muting sequence

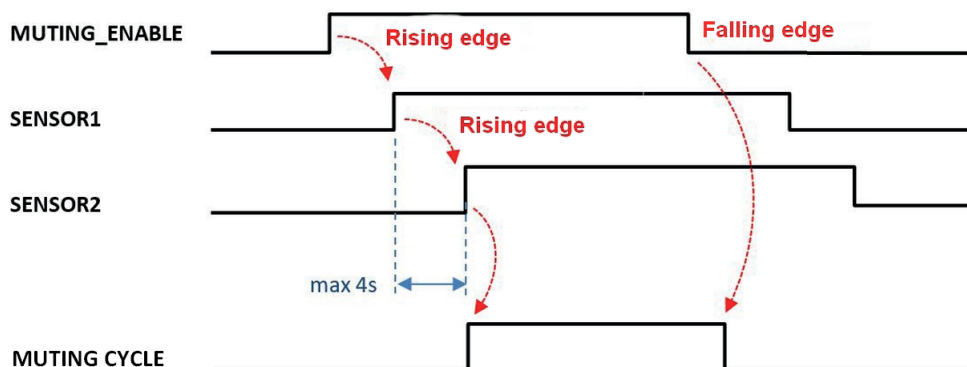

PARTIAL MUTING

Three types of partial Muting are distinguished and, for all, the “Partial Muting” input pin (pin 6 of the M12 connector of the Active Element) must be used.

1) Partial Muting with Enable (option not available for 2B Models)

With this option, the Partial Muting function is normally deactivated. To activate this function, the input signal (pin 6 of the Active Element) must switch from LO to HI (rising edge) before starting the Muting cycle. The variation of this input signal enables the Partial Muting function only for the first n selected beams (e.g. with 2 beams as in figure below).

➔ **This activation only applies to a STAND-ALONE MUTING CYCLE; It is therefore necessary to reconfirm Partial Muting activation before any new Muting function request (refer to the timing below).**

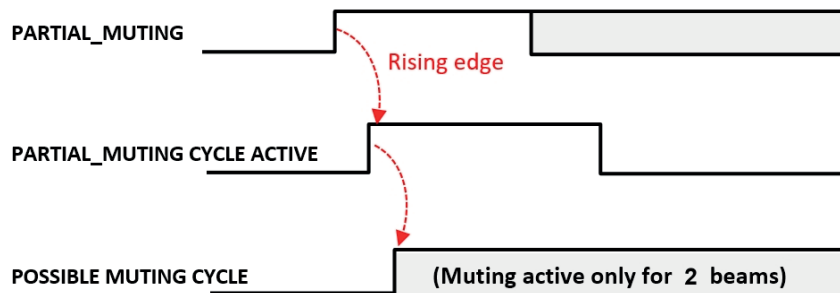
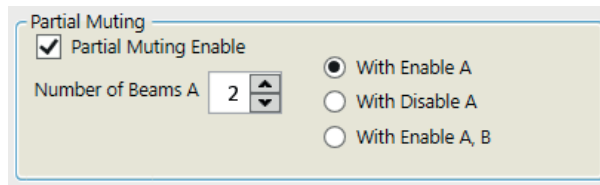

2) Partial Muting with Disable (option not available for 2B Models)

With this option the Partial Muting function is normally active (e.g. with 10 beams as in figure below). To activate this function, the input signal (pin 6 of the Active Element) must switch from LO to HI (rising edge) before starting the Muting cycle. The changing of that input signal therefore disables the Partial Muting function.

➔ **This activation only applies to a STAND-ALONE MUTING CYCLE; it is therefore necessary to reconfirm the partial Muting deactivation before any new Muting function request (refer to the timing below).**

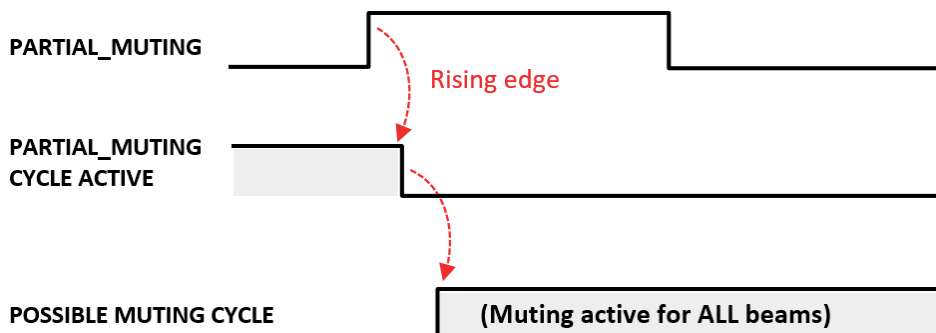
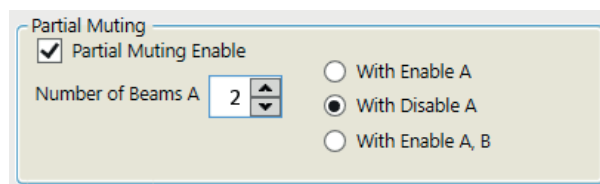

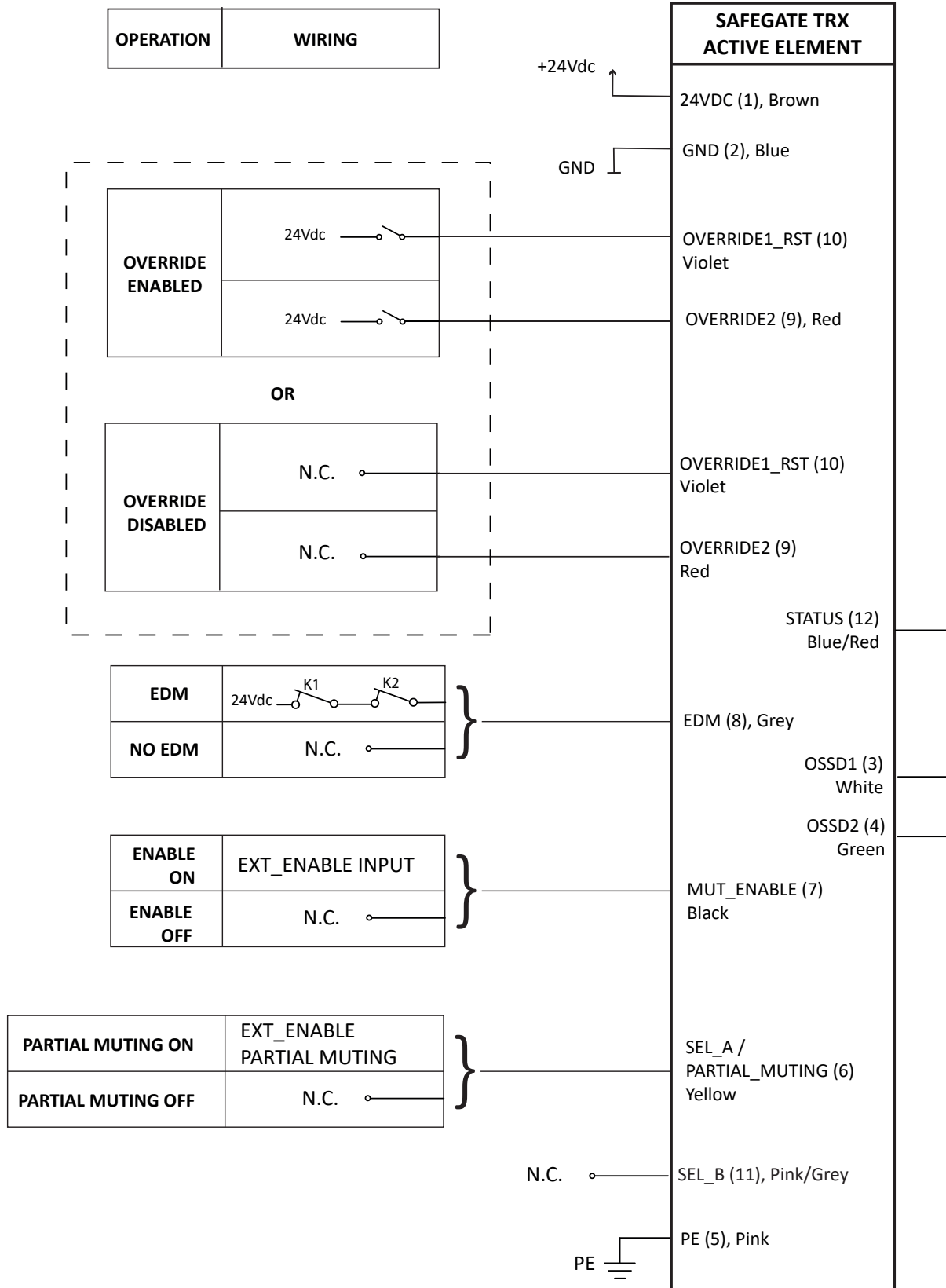

8541205 - rev.7 - 10/07/2023

APPENDIX B: SMP - SMPO MODELS WIRING SAMPLE
5 - SOFTWARE CONFIGURATION

8541205 - rev.7 - 10/07/2023

S, SO MODELS ELECTRICAL CONNECTIONS



Before proceeding to the electrical connections make sure that the available power supply voltage is in accordance with the data specified in the technical data.

-  **The Emitter and Active element must be powered at a 24Vdc±20% (PELV, in compliance with the standard EN 60204-1 (Chapter 6.4)).**
-  **Make sure the connector is screwed down tightly to ensure correct barrier operation.**
-  **In order to ensure the declared Environmental Protection Degree (IP65-IP67), it is mandatory to protect the unused connectors with the provided protection caps.**

PRECAUTIONS

- Make the connection to earth before making any other connections.
- Perform all connections before energizing Safegate.
- The ground connection (0VDC) must be common to all system components.

WARNINGS ON CONNECTION CABLES

-  **Conductor Size: 0,25÷2,5 mm².**
-  **It is recommended to keep SAFEGATE's power supply separate from that of other electrical power equipment (electric motors, inverters, frequency changers) or other sources of disturbance.**
-  **For connections more than 20 m long, cables with a section of at least 0.5 mm² must be used (AWG16), (1 mm² for lengths over 50 m).**

ACTIVE ELEMENT CONNECTIONS

("Table 1", page 52)

("Table 2", page 52)

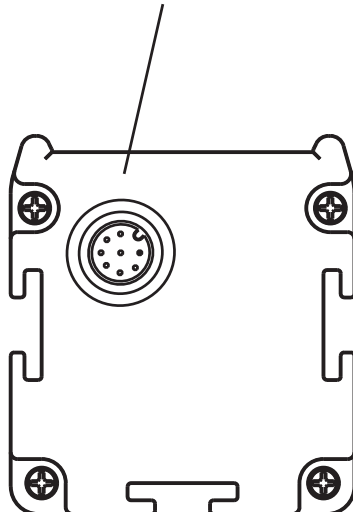
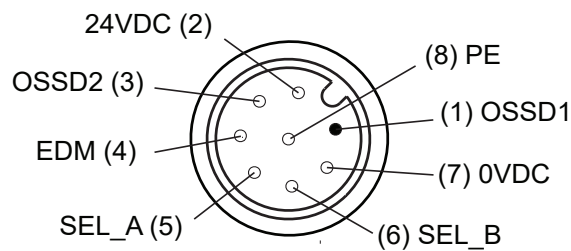

Table 1
MAIN MALE CONNECTOR – M12- 8-PIN

PIN	COLOUR	SIGNAL	IN/OUT	DESCRIPTION	ELECTRICAL LEVEL
1	White	OSSD1	Output	STATIC SAFETY OUTPUT	PNP active high
2	Brown	24VDC	-	POWER SUPPLY 24VDC	-
3	Green	OSSD2	Output	STATIC SAFETY OUTPUT	PNP active high
4	Yellow	EDM	Input	K1/K2 FEEDBACK	Feedback from external counters
5	Grey	SEL_A	Input	OPERATING MODE CONFIGURATION	Refer to the table " SELECTION OF OPERATING MODES ", page 52
6	Pink	SEL_B	Input	OPERATING MODE CONFIGURATION	Refer to the table " SELECTION OF OPERATING MODES ", page 52
7	Blue	0VDC	-	POWER SUPPLY 0VDC	-
8	Red	PE	-	EARTH CONNECTION	-

➔ **When connecting high inductive loads to OSSDs, use suitable voltage suppressors on the outputs.**

⚡ **In free protected area conditions, the Active element provides a voltage of 24VDC on BOTH outputs. Therefore, the established load must be connected between BOTH output terminals and the 0VDC.**

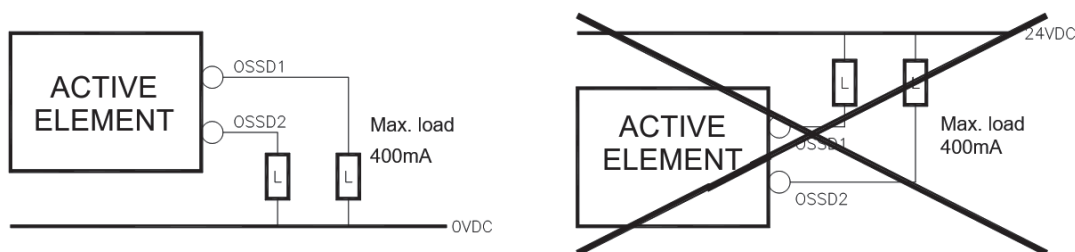
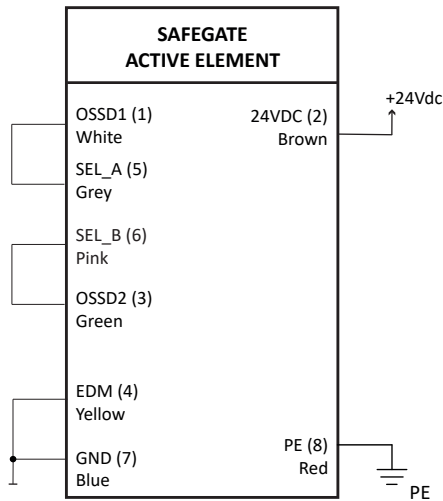

Table 2
SELECTION OF OPERATING MODES

CONNECTIONS			OPERATION
EXT_SEL_A (PIN 5) connected to : ext_OSSD1 (PIN 1)	EXT_SEL_B (PIN 6) connected to : ext_OSSD2 (PIN 3)	EXT_K1_K2 (PIN 4) connected to : 0VDC	AUTOMATIC no EDM
EXT_SEL_A (PIN 5) connected to : ext_OSSD2 (PIN 3)	EXT_SEL_B (PIN 6) connected to : ext_OSSD1 (PIN 1)	EXT_K1_K2 (PIN 4) connected to : 24VDC (through series of contacts N.C. of external relays)	AUTOMATIC with EDM
EXT_SEL_A (PIN 5) connected to : 24VDC (PIN 2)	EXT_SEL_B (PIN 6) connected to : 24VDC (PIN 2) (through the RESTART pushbutton)	EXT_K1_K2 (PIN 4) connected to : 0VDC	MANUAL no EDM
EXT_SEL_A (PIN 5) connected to : 24VDC (PIN 2) (through the RESTART pushbutton)	EXT_SEL_B (PIN 6) connected to : 24VDC (PIN 2)	EXT_K1_K2 (PIN 4) connected to : 24VDC (through series of contacts N.C. of external relays)	MANUAL with EDM

APPENDIX C: S, SO MODELS WIRING SAMPLES

MODE OF OPERATION: AUTOMATIC NO EDM



MODE OF OPERATION: MANUAL NO EDM

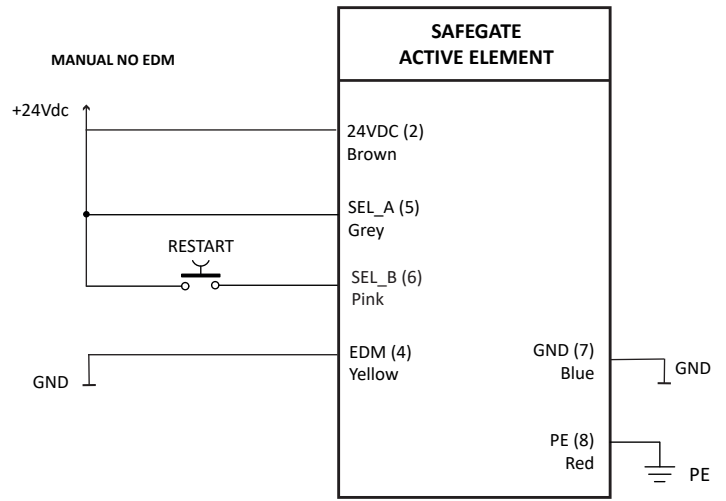

MODE OF OPERATION: AUTOMATIC WITH EDM

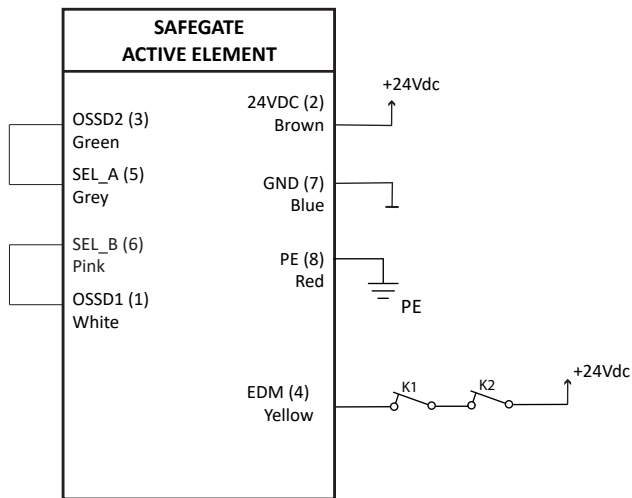

MODE OF OPERATION: MANUAL WITH EDM

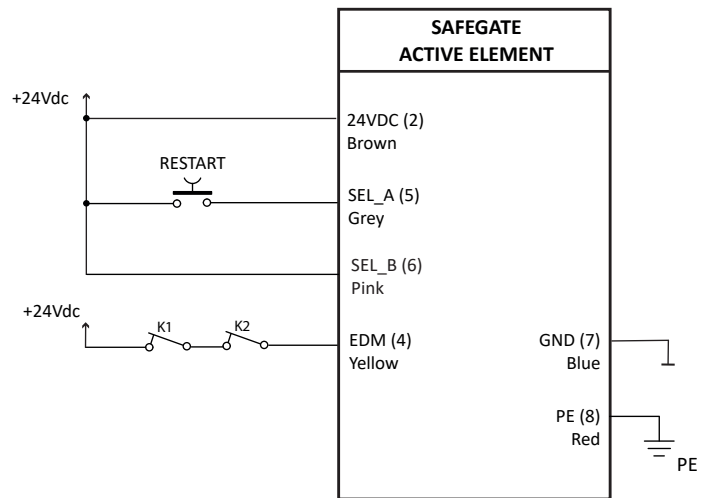

S-A, SO-A MODELS ELECTRICAL CONNECTIONS

Before proceeding to the electrical connections make sure that the available power supply voltage is in accordance with the data specified in the technical data.

The Emitter and Active element must be powered at a 24Vdc±20% (PELV, in compliance with the standard EN 60204-1 (Chapter 6.4)).

Make sure the connector is screwed down tightly to ensure correct barrier operation!

In order to ensure the declared Environmental Protection Degree (IP65-IP67), it is mandatory to protect the unused connectors with the provided protection caps.

PRECAUTIONS

- Make the connection to earth before making any other connections.
- Perform all connections before energizing Safegate.
- The ground connection (0VDC) must be common to all system components.

WARNINGS ON CONNECTION CABLES

→ **Conductor Size: 0,25÷2,5 mm².**

→ **It is recommended to keep SAFEGATE's power supply separate from that of other electrical power equipment (electric motors, inverters, frequency changers) or other sources of disturbance.**

→ **For connections more than 20 m long, cables with a section of at least 0.5 mm² must be used (AWG16), (1 mm² for lengths over 50 m).**

ACTIVE ELEMENT CONNECTIONS

("Table 3", page 55)

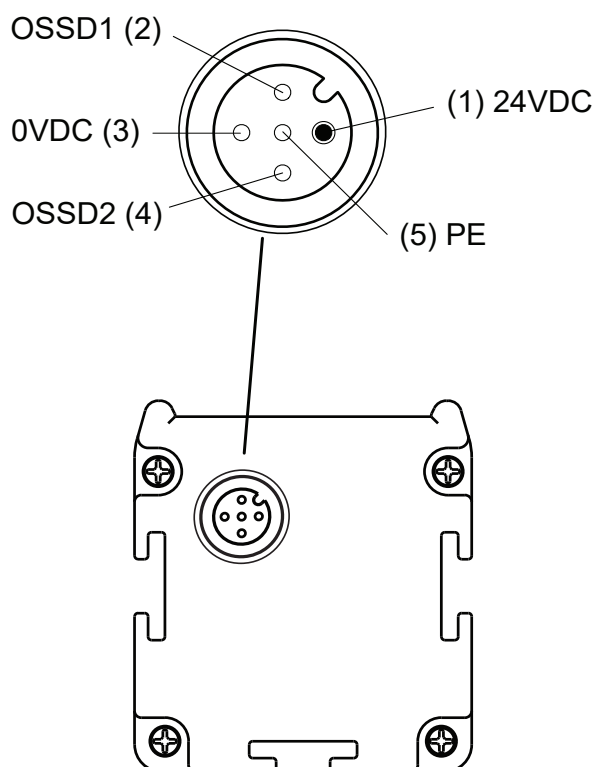
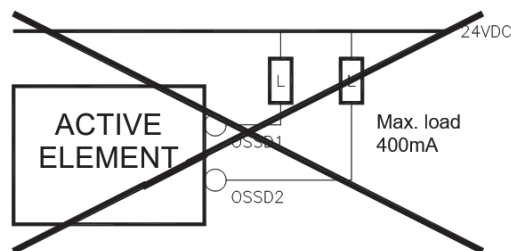
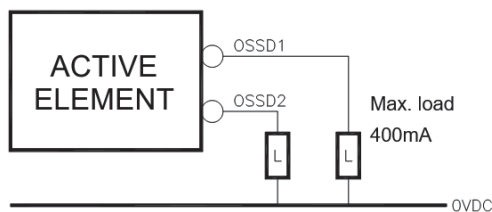

Table 3
MAIN MALE CONNECTOR - M12 - 5 PIN

PIN	COLOUR	SIGNAL	IN/OUT	DESCRIPTION	ELECTRICAL LEVEL
1	Brown	24VDC	-	POWER SUPPLY 24VDC	-
2	White	OSSD1	Output	STATIC SAFETY OUTPUT	PNP active high
3	Blue	0VDC	-	POWER SUPPLY 0VDC	-
4	Black	OSSD2	Output	STATIC SAFETY OUTPUT	PNP active high
5	Grey	PE	-	EARTH CONNECTION	-

➔ **When connecting high inductive loads to OSSDs, use suitable voltage suppressors on the outputs.**

⚡ **In free protected area conditions, the Active element provides a voltage of 24VDC on both outputs. Therefore, the established load must be connected between both output terminals and the 0VDC.**



AUTOMATIC OPERATION

In Automatic operating mode, the OSSD1 and OSSD2 safety outputs follow the status of the light curtain:

- with guarded area free, the outputs are ON.
- with guarded area occupied, the outputs are OFF.

⚡ **If the SAFEGATE light curtain is used in AUTOMATIC mode, it will not be equipped with a start/restart interlock circuit. In most applications, this safety function is mandatory. Carefully evaluate the risks analysis of your own application.**

TEST FUNCTION

The SAFEGATE barrier system features an automatic self-diagnosis function that enables it to detect response time malfunctions (this time is declared for each model).

This fault detection system is always active and does not require any external intervention.

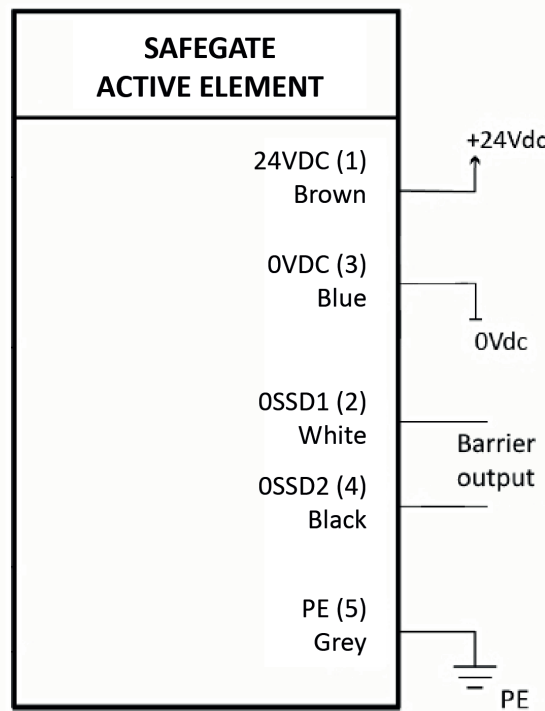
APPENDIX D: S-A, SO-A MODELS WIRING SAMPLES

LIGHT SIGNALS

SAFEGATE is equipped with an Active Element label with leds to signal its operating condition in real time. In addition SO, SO-A, SMO, SMPO models are equipped with a LED signal lamp integrated in the upper cap. Refer to the following tables to recognize active alarms.



ACTIVE ELEMENT SIGNALS (SM, SMO, SMP, SMPO)



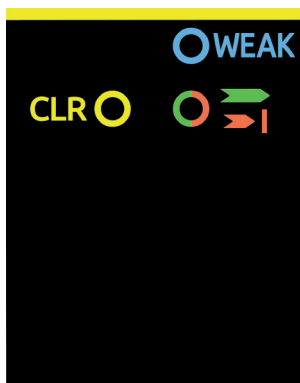



LED						MEANING
PRG	COM / WEAK	CLR	MUT	OVR	S1 S2 S3 S4	
Blue						Curtain programmed via USB
	Orange					Communication with active PC
	Blue					Weak signal
		Yellow				Curtain awaiting RESTART (clear gate)
			Green			Normal operation (clear gate)
			Red			Occupied gate
			Red Flashing			Detected failure (see "TROUBLESHOOTING")
				Yellow		Muting active
				Yellow		Override active
				Yellow Flashing		Override request
					Yellow	Sensor interrupted
Blue Flashing						No barrier programming
Blue Flashing			Red Flashing			Detected double programming (hardware and software)

ACTIVE ELEMENT SIGNALS (S, SO, S-A, SO-A)

	LED (OR NUMBER OF BLINKS)			INDICATION (OR FAULT DIAGNOSIS)	
				Model S-A	Model S
POWER ON			ON	MANUAL mode selected	
			OFF	AUTOMATIC mode selected	
		ON			Feedback K1/K2 (EDM) enabled
		OFF			Feedback K1/K2 (EDM) disabled
SIGNALS	Green			Normal operation (gate clear, OSSD outputs ON)	
	Green	ON		Indicazione di segnale ricevuto debole (gate clear, OSSD outputs ON)	
			ON		Curtain awaiting for RESTART signal (gate clear)
	Red			Gate occupied (OSSD outputs OFF)	
	Red blinking			Failure detected (see DIAGNOSTIC of the table)	
DIAGNOSTIC	2 blinks red			Configuration error: verify connector wiring	
	3 blinks red				Error static EDM: verify connector wiring at power on
	3 blinks red		3 blinks yellow		Error dynamic EDM opening: verify connector wiring (pin 4)
	4 blinks red			Error OSSD outputs	
	5 blinks red	Off or 5 blinks	Off or 5 blinks	Microcontroller error: Contact Reer after sales service	
	6 blinks red	Off or 6 blinks	Off or 6 blinks	Microcontroller error: Contact Reer after sales service	
	7 blinks red			Generic default board error: Contact Reer after sales service	
	8 blinks red			Interfering Emitter Detected: Verify the presence of another curtain not correctly positioned (see section "MULTIPLE SYSTEMS")	

ACTIVE ELEMENT SIGNALS (INTEGRATED LAMP)

INTEGRATED LAMP

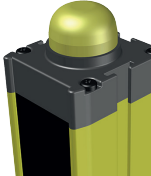
						
	Blinking				Yellow/red blinking	Blinking
BREAK <i>Occupied curtain with at least one occupied beam</i>	FAIL <i>Curtain in error condition</i>	CLEAR <i>Curtain awaiting RESTART</i>	GUARD <i>Normal operation condition</i>	MUTING <i>Muting underway</i>	OVERRIDE (Request)	OVERRIDE (In progress)

LIGHT	MEANING
Yellow/Green	Curtain awaiting RESTART (gate clear)
Green	Normal operation (gate clear)
Red	Occupied gate
Red Flashing	Detected failure (-> DIAGNOSTICS)
Yellow	Muting active
Yellow Flashing	Override active
Yellow/Red	Override request

ACTIVE ELEMENT - FAULT DIAGNOSIS

→ In SMP, SMPO models in addition to the corresponding led, when the operator connects SAFEGATE to Computer via USB, a POP-UP window with the error code appears on the monitor.



NUMBER OF FLASHINGS						ERROR	POSSIBLE CAUSE
	CLR	MUT	OVR	S1 S2	S3 S4		
2						Configuration error SEL_A/SEL_B/EDM	Pin 6-8-11 connections on the male connector
2				2 (S1/S2)		Inconsistency between red and blue connector selection for S2 wiring and the physical wiring of S2	Wire S2 inconsistency with the selected wiring option (red or blue connector)
2		2				STATUS input failure	Pin 12 connections on the RX male connector
2			2			OVERRIDE_1 / OVERRIDE_1 input failure	Pin connections 9-10 on the male connector on the RX
2		2	2			External/Internal MUTING LAMP failure	Connections on the auxiliary lamp connector
3						Wrong EDM configuration	Pin 8 connections on the male connector
3	3					EDM feedback failure	Contact connectors EDM Power Contactors
3				3		SENSOR input failure	Pin connections 2-4 on the sensor connectors
4						OSSD1 / OSSD2 error	3-4 pin connectors on the male connector
5						MAIN CARD ERROR	Contact ReeR after sales service
5	5					BASE SHEET (EEPROM) error	Contact ReeR after sales service
5			5			MAIN CARD ERROR	Contact ReeR after sales service
6						MAIN CARD (Microcontroller) error	Contact ReeR after sales service
6	6					GENERIC DEFAULT BOARD ERROR	6-7-8-9-10-11 pin connections on the male connector
6		6				Beam error	Contact ReeR after sales service
6			6			24VDC power supply overload	Eventual short-circuit on OSSD outputs
6		6	6			GENERIC DEFAULT BOARD ERROR	Contact ReeR after sales service
7						Receiving beams failure	Contact ReeR after sales service
8						Interfering Emitter Detected	Verify the presence of another curtain not correctly positioned (see section "Multiple Systems")

TECHNICAL SPECIFICATIONS

TECHNICAL FEATURES		
Safety	Type 4	EN 61496-1:2013 IEC 61496-2:2013
	SIL 3	IEC 61508-1: (ed.2) IEC 61508-2: (ed.2) IEC 61508-3: (ed.2) IEC 61508-4: (ed.2)
	PL e	EN ISO 13849-1:2015
	Cat. 4	EN ISO 13849-1:2015
Range	0...8 m	
Multibeam	2 / 3 / 4 beams	
Power supply	24VDC ± 20%	
Power consumption	3 W	
Connections	Power supply connector on Active Element: <ul style="list-style-type: none"> • M12 - 5 Pin Male: (S-A, SO-A models) • M12 - 8 Pin Male: (S, SO models) • M12 - 12 Pin Male: (SM, SMO, SMP, SMPO models) Muting sensor connectors / Muting lamp / Configuration: <ul style="list-style-type: none"> • M12 - 5 pin Female 	
Configuration	Hardware on Active Element connector S, SO, SM, SMO models Hardware or software with USB connection <-> PC on SMP, SMPO models	
Conductor dimensions	0,25...2,5 mm ² (0,5 mm ² with length > 20 m / 1 mm ² with length > 50 m)	
Max connections length	100 m	
Safety Outputs (OSSDs)	2 PNP – 400mA @ 24VDC	
STATUS Output	PNP – 100mA @ 24VDC (shows the condition of the OSSD outputs) *	
EDM input	Available on Active Element, selectable *	
Restart Auto/Manual	Available on Active Element, selectable *	
Response time	5,5 ms	
Signals and diagnostics	LED Signals on Active Element Label Models SO, SO-A: Indication of CURTAIN STATUS Models SMO, SMPO: Indication of MUTING / OVERRIDE / CURTAIN STATUS with integrated lamp in the upper Active Element cap, LED technology	
Operating temperature	-30°C ÷ +55°C	
Degree of protection	IP 65 and IP 67	
Section Size (l x h)	50mm x 55mm	

* S-A, SO-A models excluded

MUTING FUNCTION (Models SM / SMO / SMP / SMPO)	
Current rating available for Muting sensors	50 mA
Muting lamp output	24VDC / 0,5 ÷ 5 W
Muting Signal Response Time (Sensors)	100 ms
Muting Signal Logical Levels (Sensors)	< 5VDC : CLEAR SENSOR 11÷30 VDC : ACTUATED SENSOR
Time-out Muting (SM/SMO models)	30 sec, ∞ (only MT4P) / 30 sec, 9 hours (all other models)
Time-out Muting (SMP/SMPO models)	Configurable via software
Muting Override	Selectable by pulse or by action maintained Configurable via software (SMP/SMPO models only)
Override max time-out time	15 minutes (renewable) Configurable via software (SMP/SMPO models only)
Max number of consecutive OVERRIDE	30
Logic muting	Crossed beams (LX / TX logic) and sequential
Muting logic (SMP / SMPO)	Fully configurable logic with REER software
Partial Muting (SMP/SMPO)	Possibility to interrupt only a selected number of beams (only on programmable models)
Tolerance time between sensor 1 and sensor 2	4 sec. Configurable via software (SMP/SMPO models only)
Muting lamp (internal)	Integrated lamp in the upper Active Element cap, LED technology
Muting enable	Pin on main connector, disabled if not required and monitored

S, SO, S-A, SO-A, SM, SMO, SMP, SMPO Multibeam MODELS			
Beams	2	3	4
Response time (ms)	5,5	5,5	5,5
PFH _d	7,42E-09	7,58E-09	7,68E-09
MTTF _d	409,0	401,0	399,4
DC _{avg}	98,5%	98,2%	99,2%
CCF	80%		

Muting Arms MA L2P TRX (TRX V) (TRX G) Logic L - 2 parallel beams (TX/RX + reflector)	
Beams	2
Response time (ms)	100
Working range (m)	0...2 (MA L2P TRX G) / (MA L2P TRX VG)
Working range (m)	0...3,5 (MA L2P TRX) / (MA L2P TRX V)

Muting Arms MA T4P TRX (TRX V) (TRX G) Logic T - 4 parallel beams (TX/RX + reflector)	
Beams	4
Response time (ms)	100
Working range (m)	0...2 (MA T4P TRX G) / (MA T4P TRX VG)
Working range (m)	0...3,5 (MA T4P TRX) / (MA T4P TRX V)

Muting Arms MZL2X TRX (TRX G) / MZL2P TRX (TRX G) - Logic L With 2 crossed/parallel photocells M TRX	
Beams	1
Response time (ms)	100
Working range (m)	0...2 (MZL2X TRX G) / (MZL2X TRX VG)
Working range (m)	0...3,5 (MZL2P TRX) / (MZL2P TRX V)

Muting Arms MZT2X TRX (TRX G) - Logic T With 2 crossed photocells M TRX	
Number of single photocell beams	1
Response time (ms)	100
Working range (m)	0...2 (MZT2X TRX G)
Working range (m)	1...3,5 (MZT2X TRX)

Muting Arms MZT4P TRX (TRX G) - Logic T With 4 parallel photocells M TRX	
Number of single photocell beams	1
Response time (ms)	100
Working range (m)	0...2 (MZT4P TRX G)
Working range (m)	1...3,5 (MZT4P TRX)

MECHANICAL DIMENSIONS

CURTAIN DIMENSIONS

➔ *The figures below are applicable to all models of the Safegate TRX family.
N.B. The number of connectors shown is purely indicative.*

2B TRX - active element with lamp

2B TRX - active element without lamp

2B TRX passive element

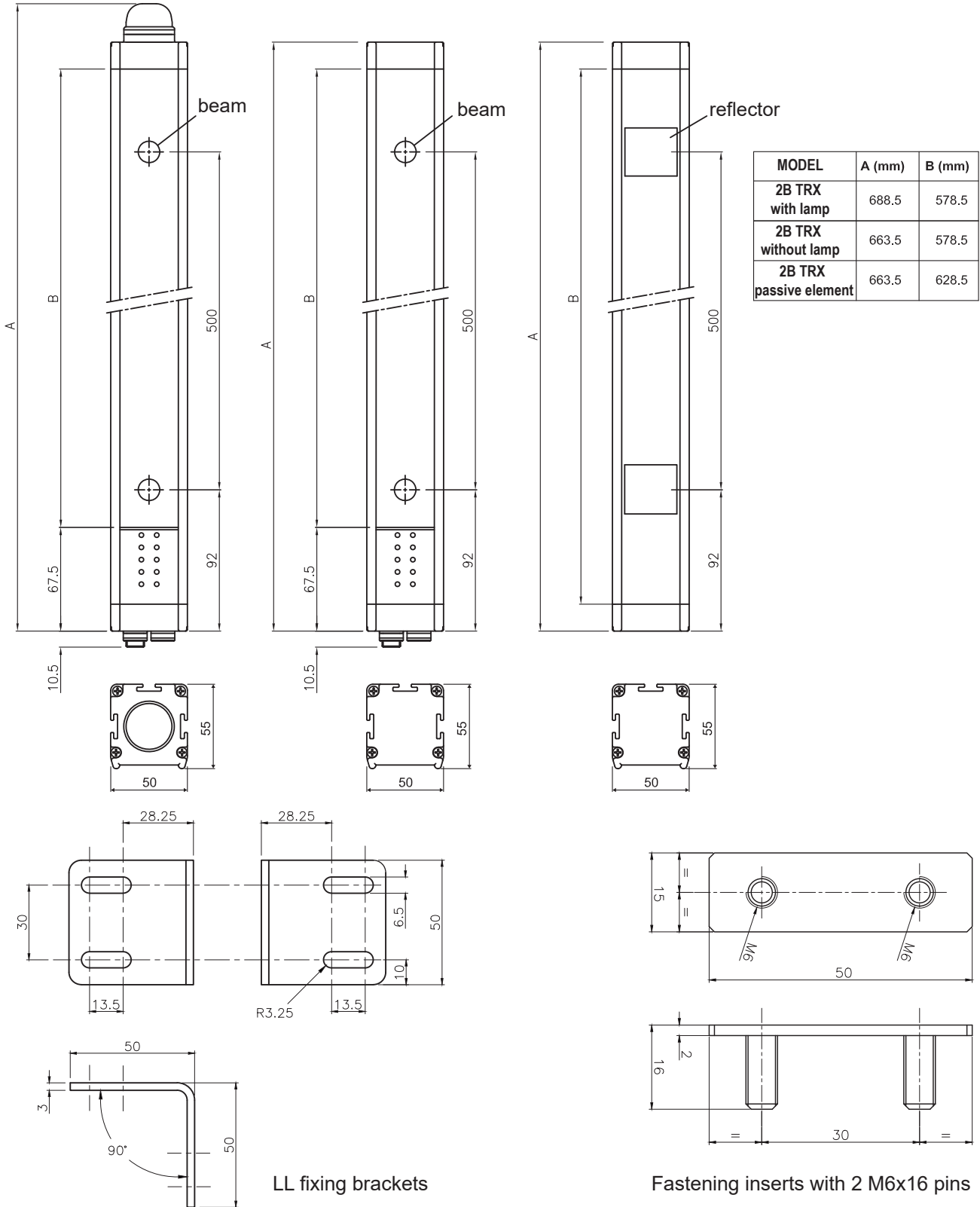

3B TRX - active element with lamp

3B TRX - active element without lamp

3B TRX passive element

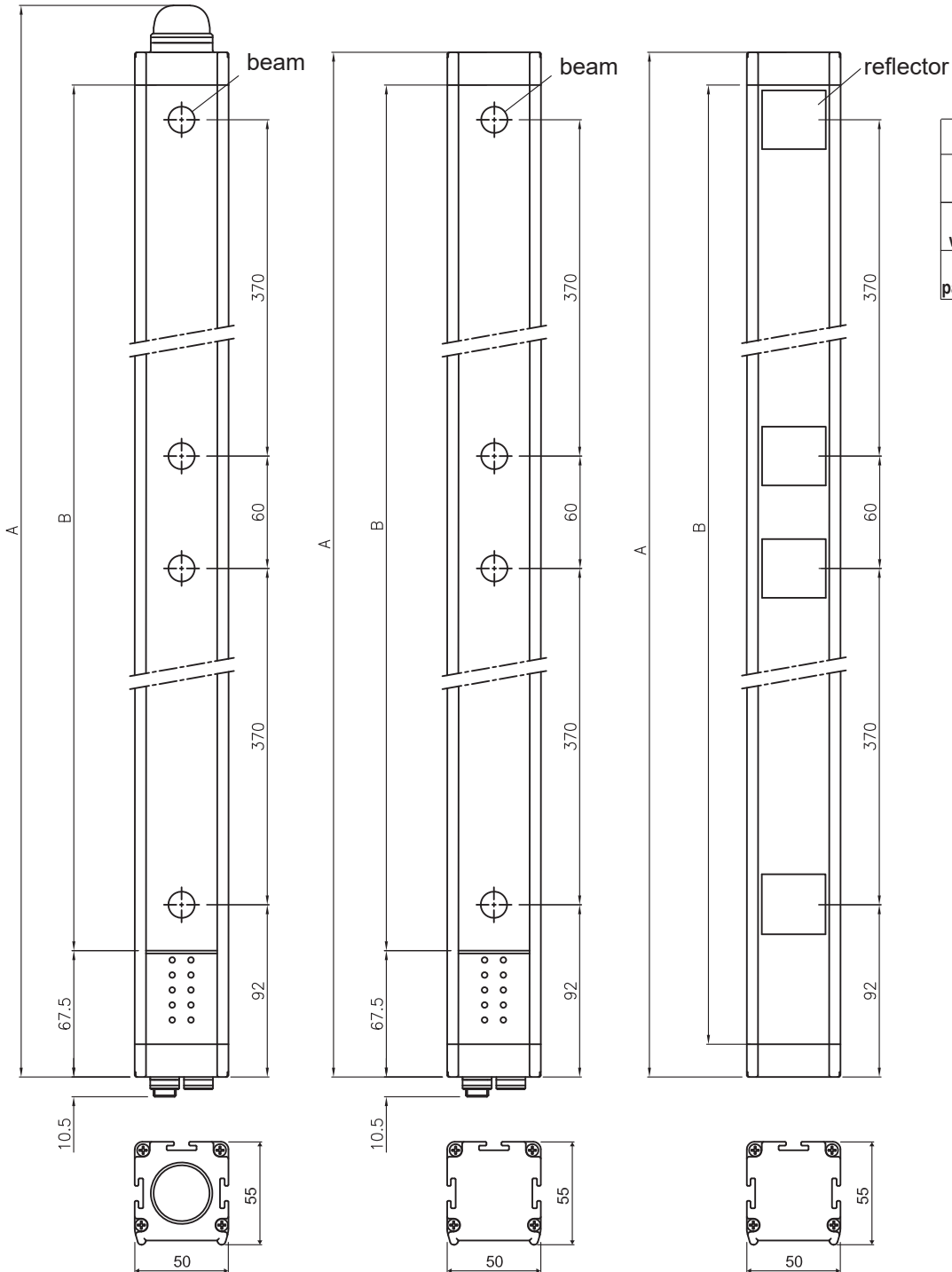

MODEL	A (mm)	B (mm)
3B TRX with lamp	959.5	849.5
3B TRX without lamp	934.5	849.5
3B TRX passive element	934.5	899.5

4B TRX - active element with lamp

4B TRX - active element without lamp

4B TRX passive element

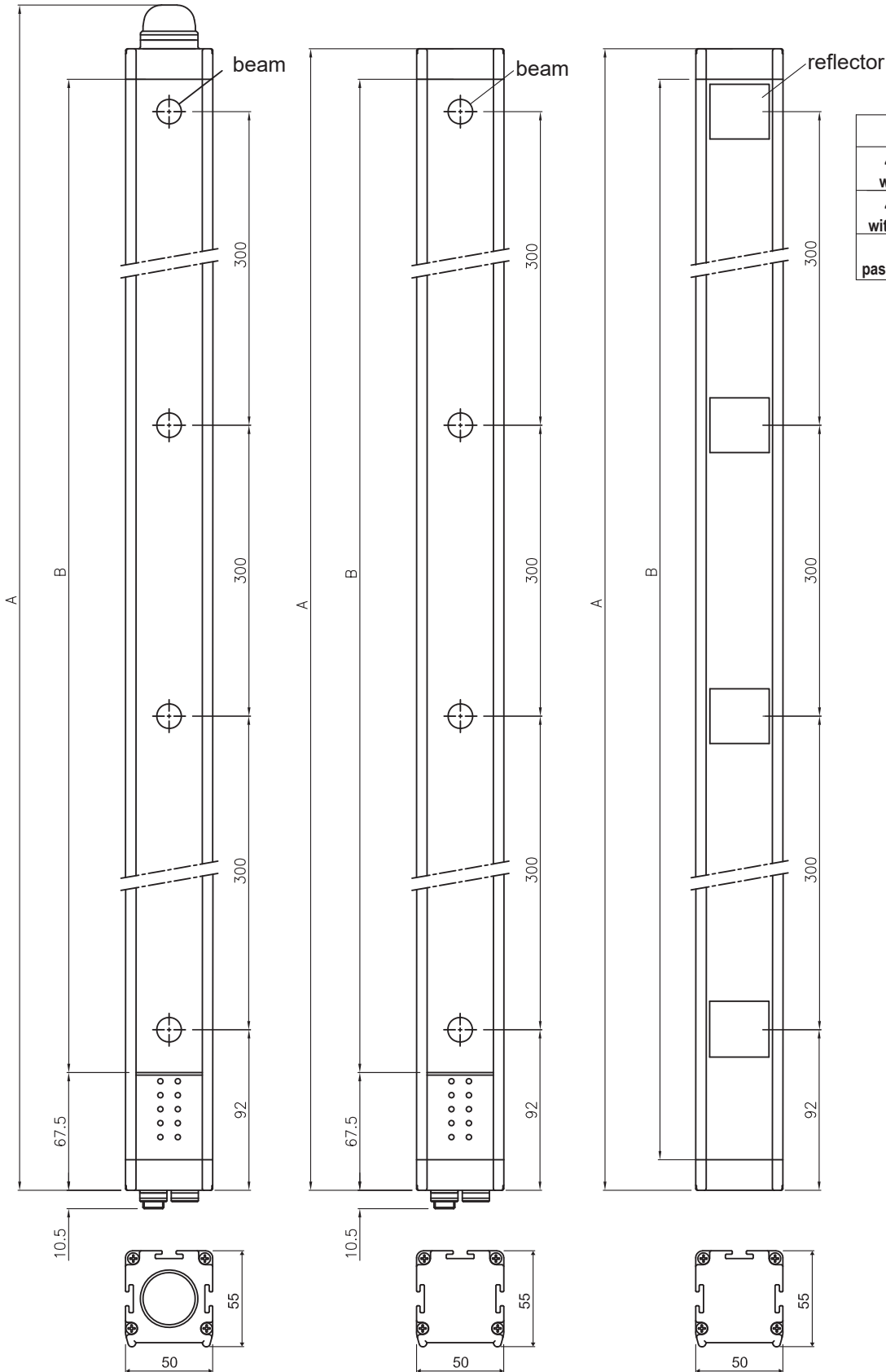

MODEL	A (mm)	B (mm)
4B TRX with lamp	1059.5	949.5
4B TRX without lamp	1034.5	949.5
4B TRX passive element	1034.5	999.5

8541205 - rev.7 - 10/07/2023

ACCESSORY DIMENSIONS

MAL2P TRX - 2 parallel beams muting arm with reflector

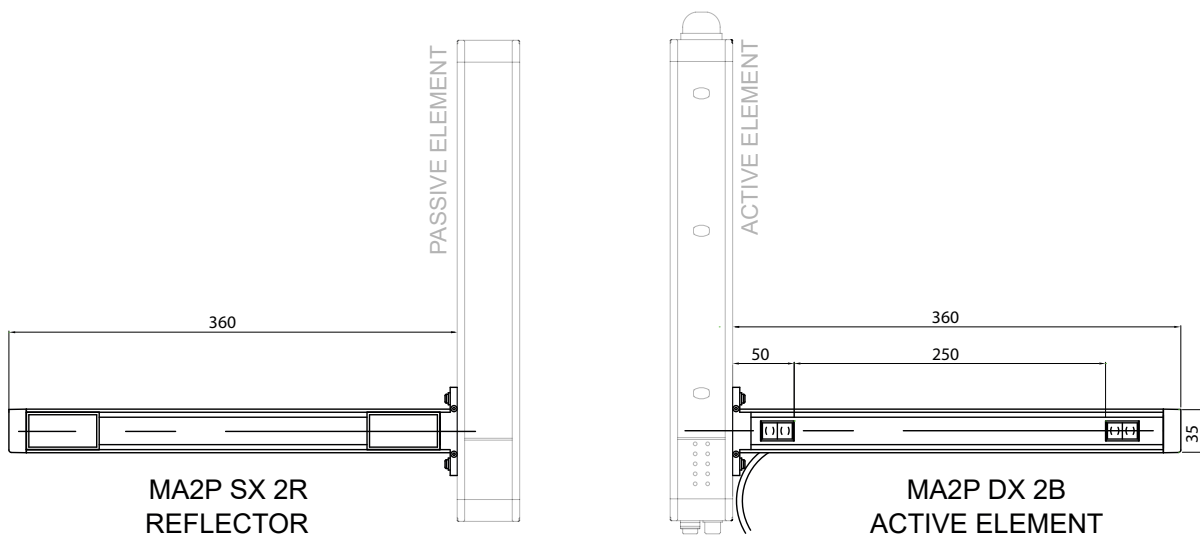

MAL2P TRX V - 2 parallel beams muting arm with reflector (high speed)

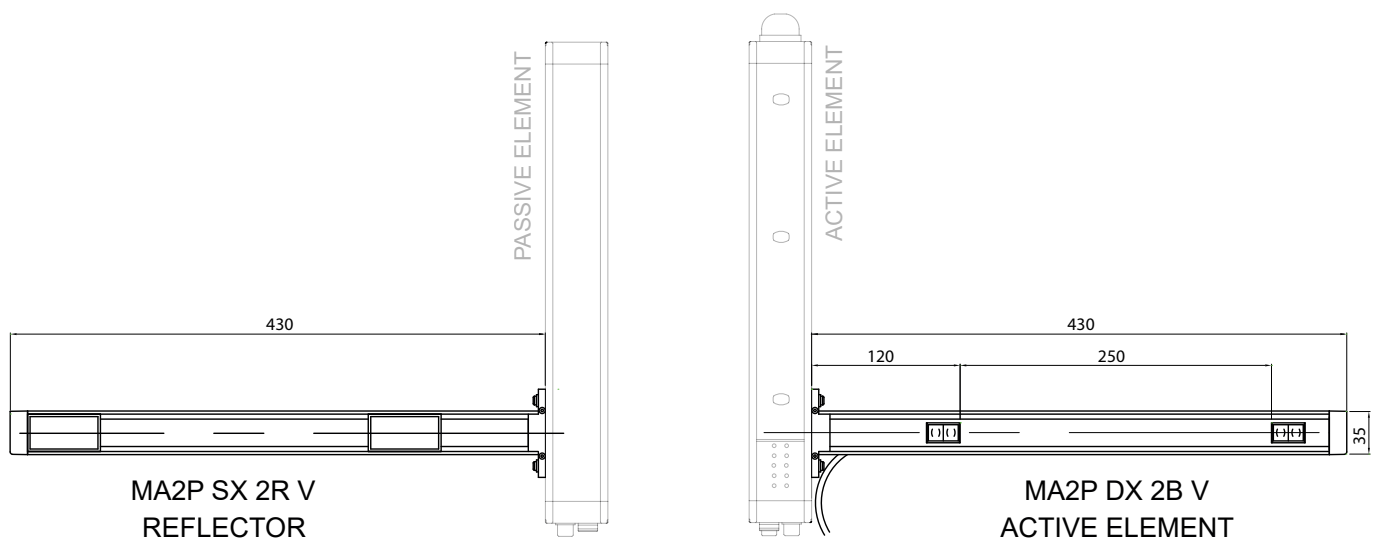

8541205 - rev.7 - 10/07/2023

MAT4P TRX - 4 parallel beams muting arm with reflector

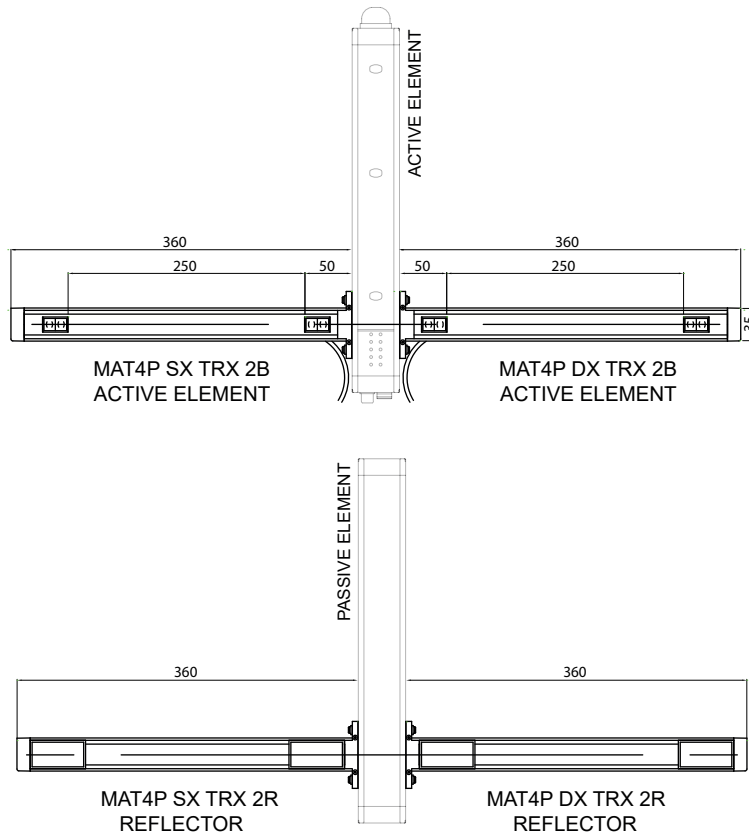

MAT4P TRX V - 4 parallel beams muting arm with reflector (high speed)

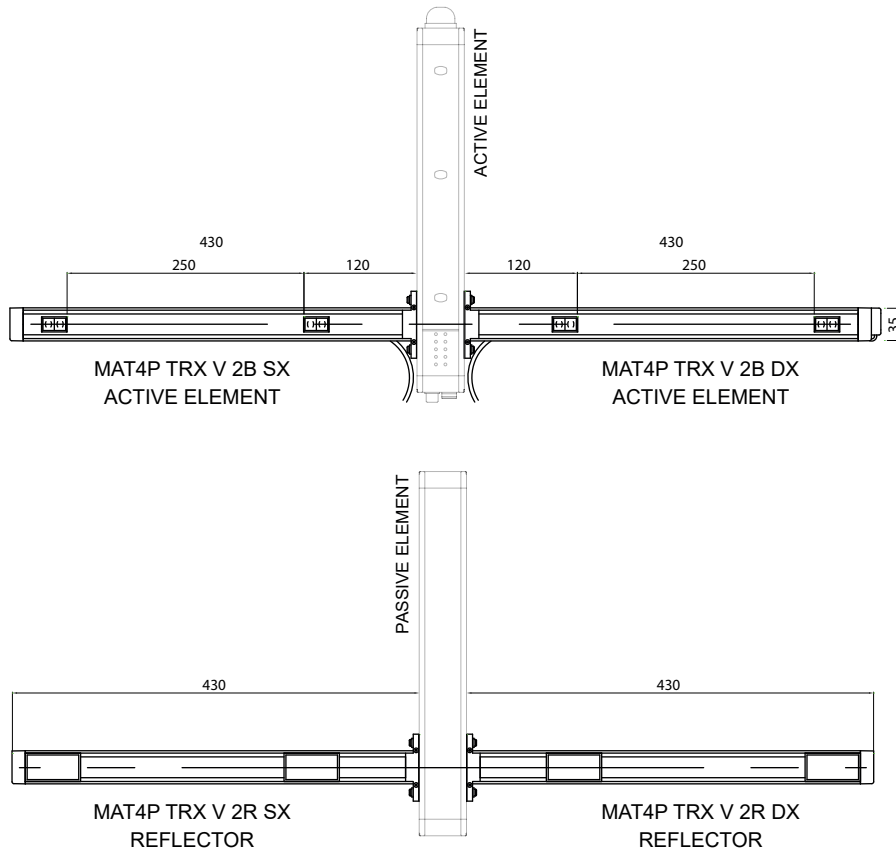

MZL2XP TRX - 2 crossed / parallel adjustable beams M TRX muting arms

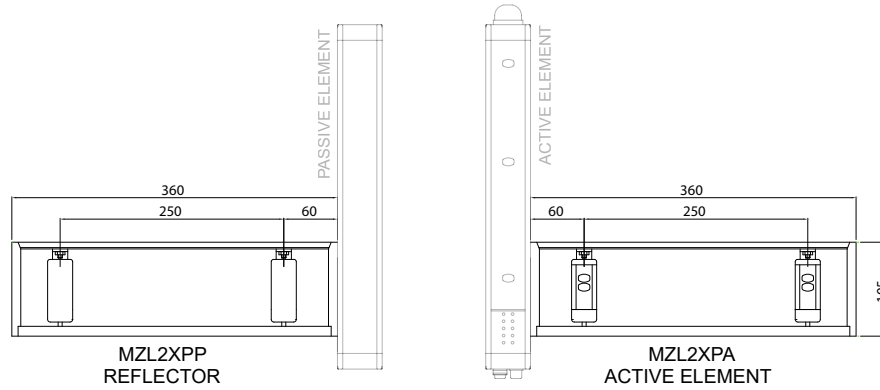

MZT2X TRX - 2 crossed beams M TRX muting arms

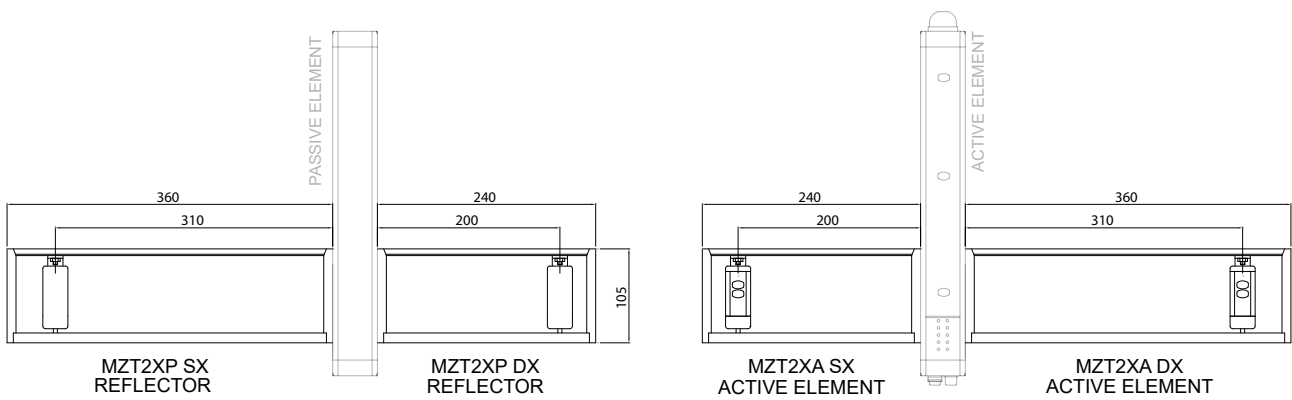

MZT4P TRX - 4 parallel beams M TRX muting arms

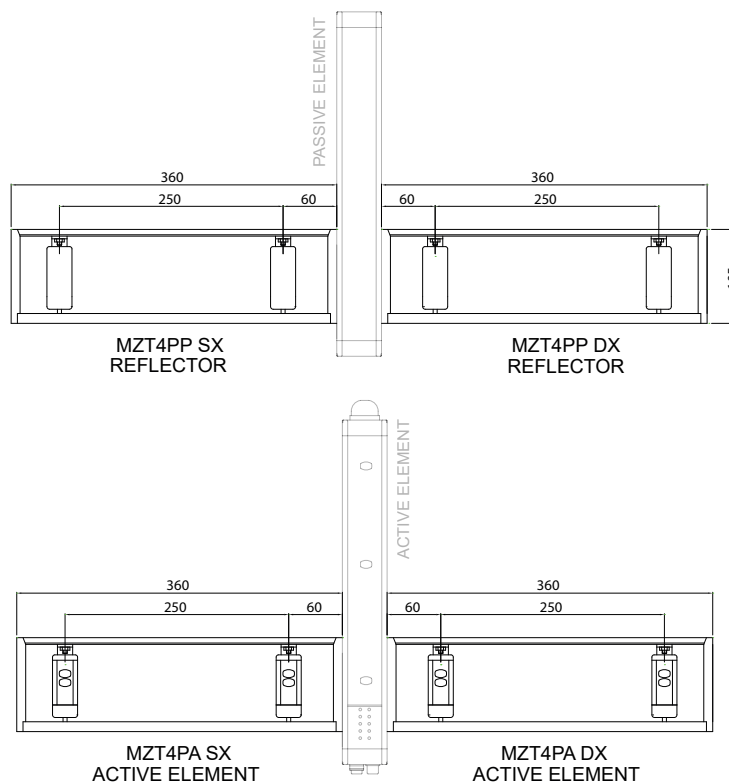

SOFTWARE SAFEGATE CONFIGURATOR

The "SAFEGATE CONFIGURATOR" application software allows configuration of the SAFEGATE curtain characteristics, allowing the operator to set all the parameters for a proper operation of the curtain and Muting function.

After verifying that the system is working correctly, the operator will no longer need connection to the PC and SAFEGATE can work autonomously.

If the operator wants to continuously monitor the curtain operation by PC, just leave the USB connection enabled with SAFEGATE.

Configuration is possible in a few simple steps through the versatile graphical interface of SAFEGATE CONFIGURATOR; let's see how.

SOFTWARE INSTALLATION

HARDWARE characteristics requested by the PC for connection

- RAM memory: 1GB (sufficient enough to operate Windows 7 SP1 + Framework 4.0)
- Hard Disk: clear Space > 500Mbyte
- USB connector: 1.1, 2.0 or 3.0

SOFTWARE characteristics requested by the PC for connection

Windows 7 with Service Pack 1 installed (or higher OS).

Microsoft Framework 4.0 (or higher) must be installed on the computer.

How to install SAFEGATE CONFIGURATOR

- Download the latest available version from the Download section of the Reer website: <https://www.reersafety.com/it/en/download/configuration-software>.
- Run the file "SetupConfigurator.exe".
- Wait for the auto-run installation program to request the SW setup.

➔ ***When the installation procedure is complete, a window appears requesting to run the program.***

➔ ***To program SMP / SMPO models it is mandatory that pin 6 and 11 of main connector on the receiver detect 0VDC (or open circuit).***

CONFIGURATION PHASES

















This section describes the main features that characterize SAFEGATE configuration software:

- GRAPHICAL INTERFACE
- CONNECTION
- PROGRAMMING
- DOWNLOAD CONFIGURATION
- CONFIGURATION VALIDATION AND LOADING
- CONFIGURATION DELETION
- PRINT REPORT
- CURTAIN ACTIVATION
- CURTAIN CONDITION MONITORING
- ERRORS DOWNLOAD
- ERRORS HISTORY

THE TOOLBAR

The standard toolbar is reproduced in the figure below and the meaning of the different icons is listed:



- 1 ->  MODIFY CURTAIN CONFIGURATION
- 2 ->  SAVING CONFIGURATION on Hard Disk
- 3 ->  LOADING CONFIGURATION from Hard Disk
- 4 ->  USER IDENTIFICATION
- 5 ->  PRINT CONFIGURATION REPORT
- 6 ->  CONFIGURATION VALIDATION
- 7 ->  CONNECTION
- 8 ->  DOWNLOAD CONFIGURATION
- 9 ->  UPLOAD CONFIGURATION
- 10 ->  DISCONNECTION (or RESTART in case of disconnected curtain)
- 11 ->  MONITOR CURTAIN CONDITION (graphics and text)
- 12 ->  CONFIGURATION HISTORY
- 13 ->  ERRORS DOWNLOAD (refer to the errors table at the end of the manual)
- 14 ->  ERROR HISTORY CANCELLATION
- 15 ->  CHANGE PASSWORD
- 16 ->  CONFIGURATION DELETION

GRAPHICAL INTERFACE

The features of the software will be described below.
At start-up, the software will show the following initial screen.

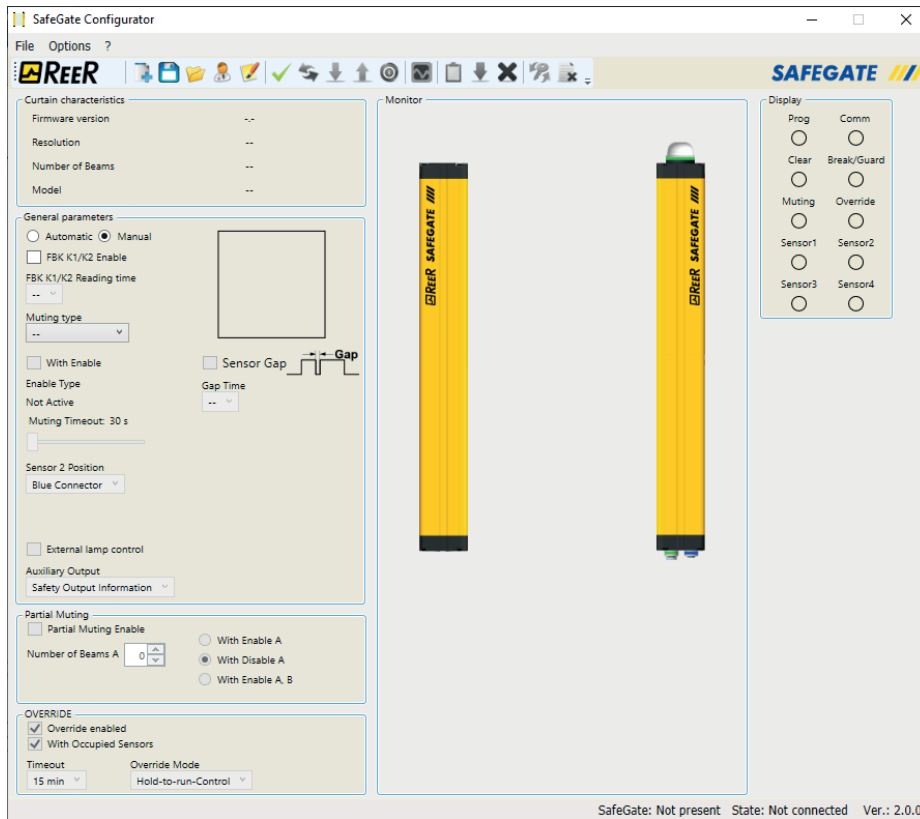

The operator can decide whether:

- to create a new configuration (icon).
- ➔ **When the operator chooses to create a new configuration or to add project information (icon); a pop-up window with the request of identification will appear on the screen.**
- to load a previously created configuration (icon).
- ➔ **To proceed with the programming, after the connection with SAFEGATE, a PASSWORD is required:**

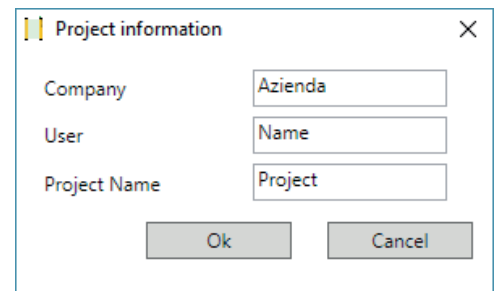

Level 1 password

- At the first system initialization the operator must use the password "" (ENTER key). The operator who knows the level 2 password is enabled to enter a new level 1 password (alphanumeric, max 8 characters).

Level 2 password

- The operator authorised to create the configuration must know a level 2 PASSWORD. At initial system initialization the operator must use the SAFEPASS password (all capital letters). The operator who knows the level 2 password is enabled to enter a new level 2 password (alphanumeric, max 8 characters).

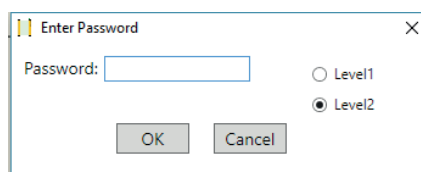

CONNECTION WITH SAFEGATE

- Connect the PC to SAFEGATE (icon )
- After entering the PASSWORD, the following screen will appear:

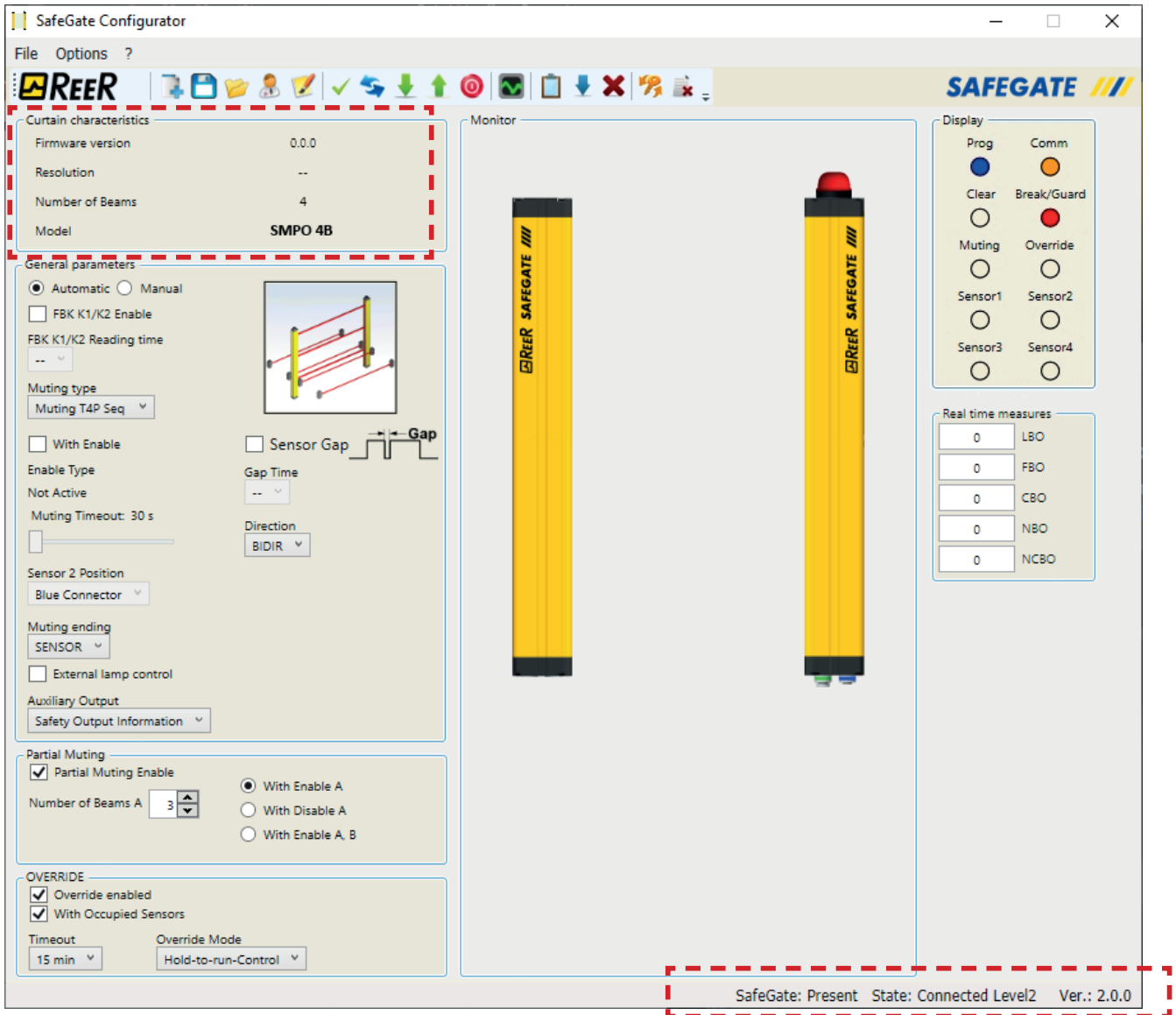

At this stage we have a STATIC reading of the SAFEGATE condition, as the curtain is still not in operation. In the boxes, the information is highlighted:

- General characteristics of the curtain
- Password Level
- Connected/Disconnected
- Software Version

DOWNLOAD CONFIGURATION

- In order to view the curtain configuration, it is necessary to request a download of the configuration

(icon )

➔ **Otherwise, the SAFEGATE configuration procedure is required.**

CURTAIN PROGRAMMING

The dotted box highlights the area to be filled for the proper programming of the curtain.

Level 2 password

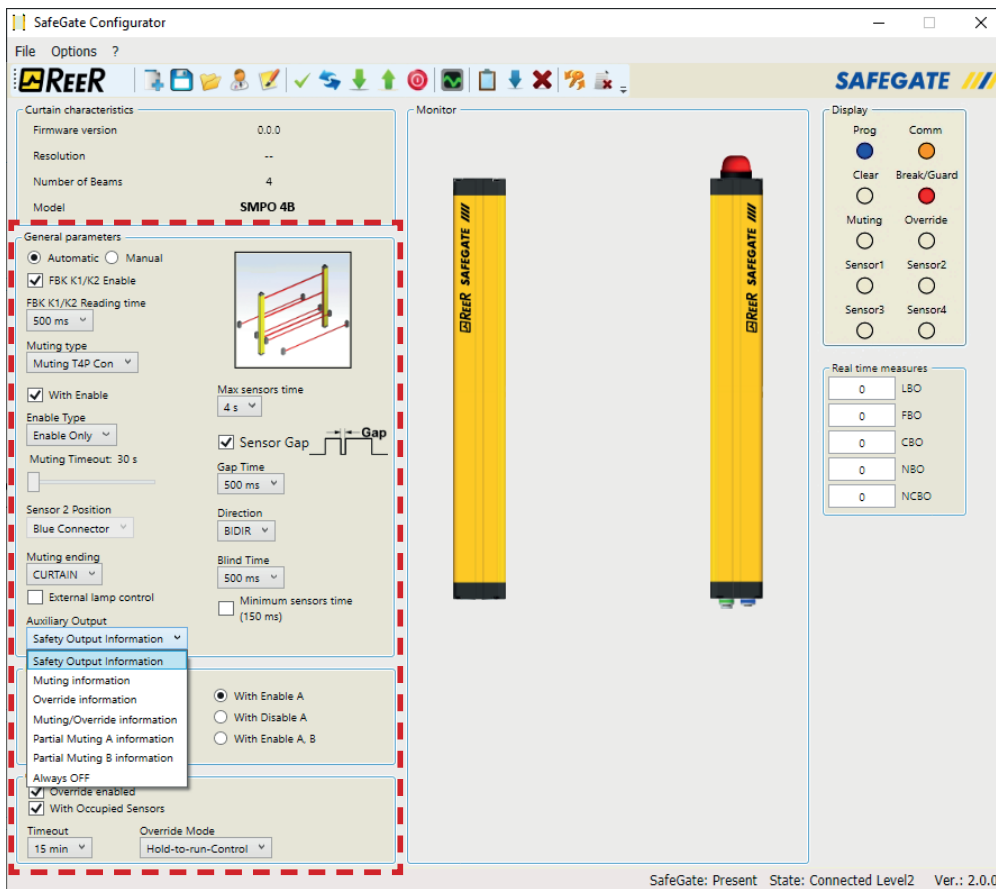

- The operator authorised to create the configuration must know a level 2 PASSWORD. At first system initialization the operator must use the SAFEPASS password (all capital letters). The designer who knows the level 2 password is enabled to enter a new level 2 password (alphanumeric, max 8 characters).

- ➔ **Programming (BLUE) and Communication (YELLOW) leds are lit during programming.**
- ➔ **Refer to the "CONFIGURATION PARAMETERS" section for the meaning of the various parameters and their possible options.**



- After the operator has properly configured the curtain, he can save that information (icon ).

CONFIGURATION VALIDATION AND LOADING

- Check the correctness of the configuration with the validation procedure (icon ).
- Then send the configuration to SAFEGATE (icon ) and confirm:

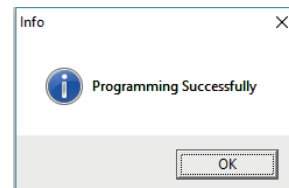
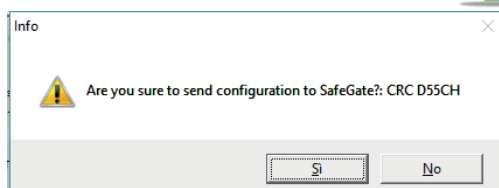

PRINT REPORT CONFIGURATION

➤ Thanks to the Report Printing feature () you can make a report (Report) of the main parameters set by the operator during configuration.

➔ **This function allows immediate verification of the configuration just set.**

 **This SAFEGATE system report assumes that configuration has been performed correctly with the SCS configuration software, in compliance with the regulations stated in the SAFETY section.**

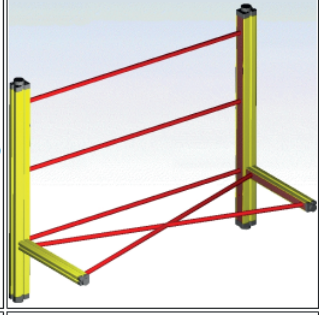
Print Report		
SafeGate Configurator Ver.: 1.0.0		
Date: 08/05/2017	CRC: D55CH	
General parameters		
Automatic		
Feedback K1_K2 disabled	-	
Muting		
Muting type	Muting L2X/L2P	
Muting Timeout	30 s	
With Enable	NO	
Concurrent time sensors	4 s	
Minimum sensors time	NO	
S2 Position	2	
End Muting Time	4.0 s	
Blind Time	500 ms	
Gap Sensors	NO	
Mandatory lamp	NO	
Partial Muting		
Partial Muting Enable	YES	
Number of Rays	6	With Disable
OVERRIDE		
Override enabled	YES	
Override Mode	Spring return key	
Timeout	15 min	
With Occupied Sensors	NO	

CONFIGURATION HISTORY

Within the configuration history file are contained the date of creation and the CRC (4-digit hexadecimal identification) of the last configurations loaded. This logfile can record up to 5 consecutive events; the register will be then overwritten starting with the least recent event.

The LOG file can be viewed using the appropriate icon in the standard menu ().

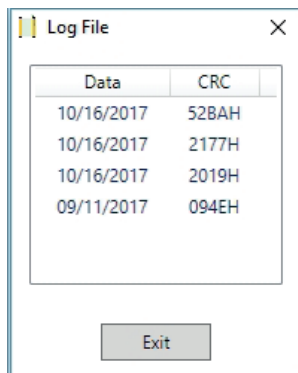

Data	CRC
10/16/2017	52BAH
10/16/2017	2177H
10/16/2017	2019H
09/11/2017	094EH

Exit

LOG ERRORS DOWNLOAD

Using the  icon, the operator can download the Errors Log file containing Error Code, Micro involved and Error Address.

Please refer to the errors table at the end of the manual to follow the appropriate corrective action.

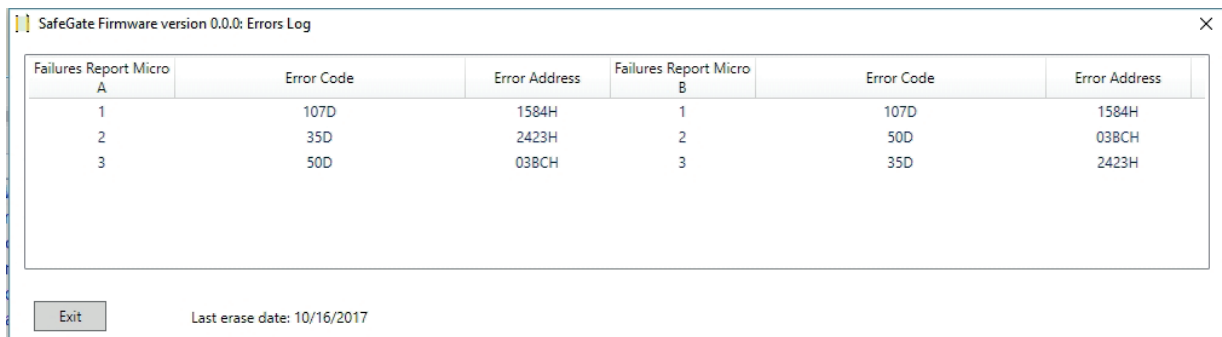

Failures Report Micro	Error Code	Error Address	Failures Report Micro	Error Code	Error Address
A			B		
1	107D	1584H	1	107D	1584H
2	35D	2423H	2	50D	03BCH
3	50D	03BCH	3	35D	2423H

Exit Last erase date: 10/16/2017

SAFEGATE ACTIVATION

The actual operation and display of the curtain status is obtained via two successive commands:

- Disconnect (icon ). SAFEGATE is now operative.
- Monitor curtain status (icon ).

CURTAIN CONDITION MONITORING

At this stage we have a DYNAMIC reading of the SAFEGATE operating condition.

In particular, they are highlighted:

- A graphic representation of the curtain, with integrated lamp (if present) with colouration in real time.
- A graphic representation of the colour-coded label in real time. Programming blue led and Communication yellow led on = *Curtain is programmed and communicating.*

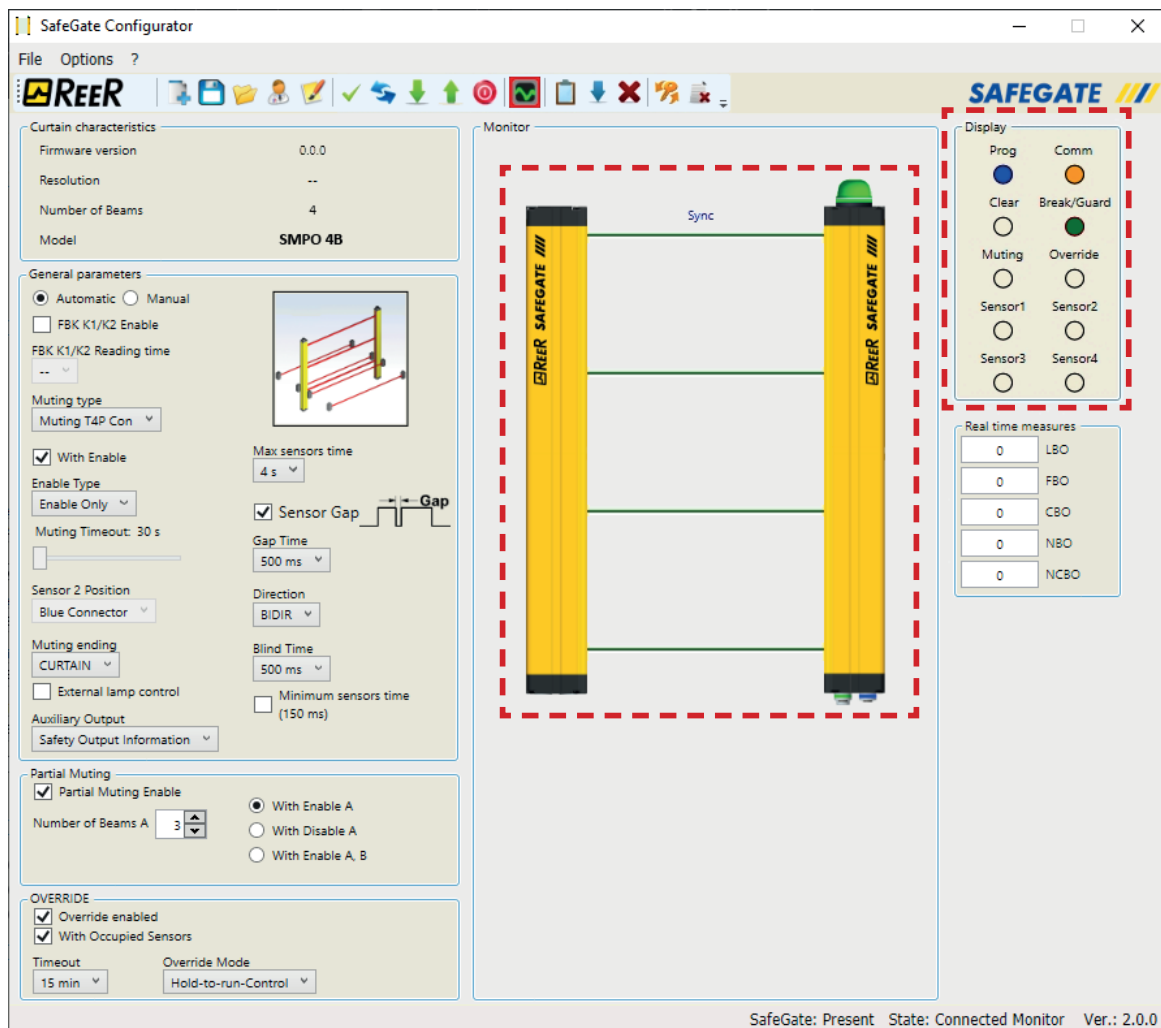

CONFIGURATION DELETION

Using the  icon, the operator can delete the configuration uploaded on the barrier (*level 2 password*).

SETTING CURTAIN GENERAL PARAMETERS

Automatic/Manual: This parameter allows you to communicate the desired operating mode to SAFEGATE (refer to section "OPERATING MODES SELECTION").

Enable FBK K1/K2: If selected, it is mandatory to read an external EDM signal (refer to section "SELECTING MODES OF OPERATION").

FBK K1/K2 reading time: Lets you set a delay in reading the external FBK signal.

Possible values: from 100 ms to 1300 ms (with 100 ms steps).

Auxiliary Output: With drop-down menu, select the meaning to be assigned to the receiver pin 12 (STATUS):

- Safety Output information
- Muting information
- Override information
- Muting/Override information
- Partial Muting A information
- Always OFF

When one of the previous options is selected, the pin 12 (STATUS) state level turn by 0VDC to 24VDC, thus indicating that the function is active.

SETTING MUTING PARAMETERS

“Concurrent” Muting

→ *The activation of the Muting function occurs as a result of the interruption of the sensors S1 and S2 (the order is not relevant) within a time between 2s and 5s decided by the operator, (or S4 and S3 with material moving in the opposite direction). Contemporaneous Muting enables the muting function to be activated by the S1, S2, S3 and S4 inputs. Preliminary condition: The Muting cycle can start if all sensors are at 0VDC and the light curtain is free.*

Parameters

With_Enable: If checked, it is possible to read the external signal of "MUT_ENABLE" (Muting Enable).

Otherwise, the Muting function is always enabled. Enable can be of two types: Enable/Disable and Enable Only. If you select it "Enable/Disable" the Muting cycle cannot start if Enable is fixed at 24VDC or 0VDC but it is activated only with one **rising edge**, if you want to disable the muting, the signal must be returned to 0VDC. In this way, the detected falling edge disables Muting in any condition. If you select it "Enable only" there is no way to disable Muting over the entire duration of the function, but you must always return Enable to 0VDC to allow a new rising edge for the next Muting cycle (refer to the "Partial Muting" section).

Muting Timeout: Allows you to set the time, variable from 10 sec to infinity, within which the Muting cycle must end, if when the cycle is not yet over, Muting is disabled immediately.

Concurrent Time Sensors: You can set the maximum time (2 to 5 seconds) that must be between the activation of two muting sensors.

Sensor Gap: With non-homogeneous pallet materials and possible "holes" in the interruption of the muting, this parameter allows filtering in the fall of the sensor signal leaving then the muting sequence unchanged. This parameter can take values from 200ms to 1000ms (with 100ms steps)

Position S2: Not allowed.

Direction: You can set the occupancy order of the sensors; if set BIDIR the occupation can take place in both directions from S1 & S2 to S3 & S4 or reverse order; if you choose UP the occupancy order is: S1 & S2 to S3 & S4 and eventually with DOWN the occupancy order is: S4 & S3 to S2 & S1.

Muting Closure: It can be of two types CURTAIN and SENSOR. By selecting CURTAIN, muting closes at the release of the protected gate, while with SENSOR closure occurs after the release of the last but one sensor.

Blind Time: Only with Muting Closure = Curtain, blind time is triggered if it is known that after the complete transit of the pallet (muting cycle closure) objects may be protruding and occupy the curtain, sending the curtain to BREAK status. During blind time, OSSD outputs remain active. The Blind Time may vary from 250 ms to 1 second.

Minimum Sensor Time: If selected, it allows Muting activation only if it is time >150 ms between activation of sensor 1 and sensor 2 (or sensor 4 and sensor 3).

External Lamp Control: If selected, the Muting lamp is compulsory.

“Sequential” Muting

➔ *The activation of the Muting function occurs following the sequential interruption of the sensors S1 and S2, and the sensors S3 and S4. If the pallet proceeds in an opposite direction the correct sequence is: S4, S3, S2, S1.*

Parameters

With_Enable: If checked, it is possible to read the external signal of "MUT_ENABLE" (Muting Enable). Otherwise, the Muting function is always enabled. Enable can be of two types: Enable/Disable and Enable Only. If you select it "Enable/Disable" the Muting cycle cannot start if Enable is fixed at 24VDC or 0VDC but it is activated only with one rising edge, if you want to disable the muting, the signal must be returned to 0VDC. In this way, the detected falling edge disables Muting in any condition. If you select it "Enable Only" there is no way to disable Muting over the entire duration of the function, but you must always return Enable to 0VDC to allow a new rising edge for the next Muting cycle (refer to the "Partial Muting" section).

Muting Timeout: Allows you to set the time, variable from 10 sec to infinity, within which the Muting cycle must end, if, when the cycle is not yet over, Muting is disabled immediately.

Sensor Gap: With non-homogeneous pallet materials and

possible "gaps" in the interruption of muting, this parameter allows filtering the drop of the sensor signal leaving then the muting sequence unchanged. This parameter can take values from 200ms to 1000ms (with 100ms steps)

Position S2: Not allowed.

Direction: You can set the occupancy order of the sensors; if set BIDIR the occupation can take place in both directions from S1 & S2 to S3 & S4 or reverse order; if you choose UP the occupancy order is: S1 & S2 to S3 & S4 and eventually with DOWN the occupancy order is: S4 & S3 to S2 & S1.

Number Beams: Makes it possible to select the number of beams that can be affected by Muting (if Partial Muting is active).

Muting Closure: It can be of two types CURTAIN and SENSOR. By selecting CURTAIN, muting closes at the release of the protected gate, while with SENSOR, closure occurs after the release of the last but one sensor.

External Lamp Control: If selected, the Muting lamp is compulsory.

“L” Muting

→ *The activation of the Muting function occurs as a result of the interruption of sensors S1 and S2 (the order is not relevant) within a time between 2s and 5s decided by the operator. The status of Muting ends after the release of the gate.*

Parameters

With Enable: If checked, it is possible to read the external signal of "MUT_ENABLE" (Muting Enable).

Otherwise, the Muting function is always enabled. Enable can be of two types: Enable/Disable and Enable Only. If you select "Enable/Disable" the Muting cycle cannot Start if Enable is fixed at 24VDC or 0VDC but is activated only by a **rising edge**; if you want to disable the muting, the signal must be returned to 0VDC. In this way, the detected falling edge disables Muting in any condition. If you select "Enable only" there is no way to disable Muting over the entire duration of the function, but you must always return Enable to 0VDC to allow a new rising edge for the next Muting cycle (refer to the "Partial Muting" section).

Muting Timeout: Allows you to set the time, variable from 10 sec to infinity, within which the Muting cycle must end, if, when the cycle is not yet over, Muting is disabled immediately.

Time Simultaneous Sensors: You can set the maximum time (2 to 5 seconds) that must be between the activation of two muting sensors.

Sensor Gap: With non-homogeneous pallet materials and possible "holes" in the interruption of the muting, this parameter allows filtering in the fall of the sensor signal leaving then the muting sequence unchanged. This parameter can take values from 200ms to 1000ms (with 100ms steps)

Position S2: The Position S2 parameter allows the operator to select the connector (blue or red) to which the external Muting S2 sensor must be connected. The **blue** connector must be selected using integrated L-arms (with output on a single connector). Using two separate sensors (with 2 connectors) the operator must select the **red** connector.

Muting end time: You can set the (from 2.5 to 6 seconds, with 500 ms steps) that must be between the release of the first sensor and the release of the dangerous gate. At the end of this time the Muting function ends.

Blind Time: Only with Muting Closure = Curtain, blind time is triggered if it is known that after the complete transit of the pallet (muting cycle closure) objects may be protruding and occupy the curtain, sending the curtain to BREAK status. During blind time, OSSD outputs remain active. The Blind Time may vary from 250 ms to 1 second.

Minimum Sensor Time: If selected, it allows Muting activation only if it is time >150 ms between activation of sensor 1 and sensor 2 (or sensor 4 and sensor 3).

External Lamp Control: If selected, the Muting lamp is compulsory.

“T” Muting

➔ **The activation of the Muting function occurs as a result of the interruption of the sensors S1 and S2 (the order is not relevant) within a time between 2s and 5s decided by the operator. The status of Muting ends after the release of the gate.**

Parameters

The screenshot shows the 'General parameters' window for 'T' Muting. It includes the following settings:

- General parameters:**
 - Automatic (radio button), Manual (radio button, selected)
 - FBK K1/K2 Enable (checkbox, checked)
 - FBK K1/K2 Reading time: 500 ms (dropdown)
 - Muting type: Muting T4P Con (dropdown)
- With Enable:**
 - With Enable (checkbox, checked)
 - Enable Type: Enable Only (dropdown)
 - Muting Timeout: 30 s (slider)
- Sensor 2 Position:** Blue Connector (dropdown)
- Muting ending:** SENSOR (dropdown)
- External lamp control:** (checkbox, checked)
- Max sensors time gap:** 4 s (dropdown)
- Sensor filtering:** (checkbox, checked)
- Filtering Time:** 500 ms (dropdown)
- Direction:** BIDIR (dropdown)
- Min sensors time gap (150 ms):** (checkbox, unchecked)

A diagram in the center shows a gate with two vertical sensors (S1 and S2) and a horizontal beam. Red lines indicate the sensor's field of view. A pulse diagram to the right shows a signal with a 'Gap' between two pulses.

With_Enable: If checked, it is possible to read the external signal of "MUT_ENABLE" (Muting Enable). Otherwise, the Muting function is always enabled. Enable can be of two types: Enable/Disable and Enable Only. If you select it "Enable/Disable" the Muting cycle cannot start if Enable is fixed at 24VDC or 0VDC but it is activated only with one rising edge, if you want to disable the muting, the signal must be returned to 0VDC. In this way, the detected falling edge disables Muting in any condition. If you select it "Enable only" there is no way to disable Muting over the entire duration of the function, but you must always return to 0VDC Enable to allow a new rising edge for the next Muting cycle (refer to the "Partial Muting" section).

Muting Timeout: Allows you to set the time, variable from 10 sec to infinity, within which the Muting cycle must end, if When the cycle is not yet over, Muting is disabled immediately.

Sensor Gap: With non - homogeneous pallet materials and possible "holes" in the interruption of the muting, this parameter allows filtering in the fall of the sensor signal leaving then the

muting sequence unchanged. This parameter can take values from 200ms to 1000ms (with 100ms steps)

Position S2: The Position S2 parameter allows the operator to select the connector (blue or red) to which the external Muting S2 sensor must be connected. The **blue** connector must be selected using sensors with output on a single connector. Using two separate sensors (with 2 connectors) the operator must select the **red** connector.

Minimum sensor time: If selected, it is only possible to activate Muting if a time > 150 ms elapses between the activation of Sensor 1 and Sensor 2 (or Sensor 4 and Sensor 3).

External Lamp Control: If selected, Muting lamp is compulsory.

PARTIAL MUTING

A SAFEGATE function concerns the possibility of limiting the muting function to a number of well-defined beams (from the first beam).

This function, called Partial Muting, has the following features:

- ➔ **It can only be enabled with the Safegate Configurator SOFTWARE: (Tick on "Partial Muting Enabling").**
- ➔ **The first beam of the Partial Muting always starts from the bottom (connection side).**
- ➔ **For more Partial Muting options explanation, refer to the section "PARTIAL MUTING" a pagina 48**

Partial Muting with Enable

When Partial Muting with ENABLE is selected after a "PARTIAL Muting" signal rising before the start of the Muting cycle, SAFEGATE enables the Partial Muting function only for the first n beams (2 in the example).

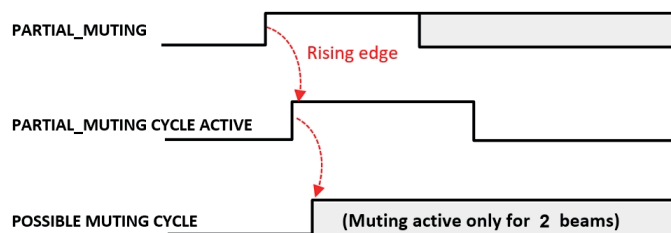
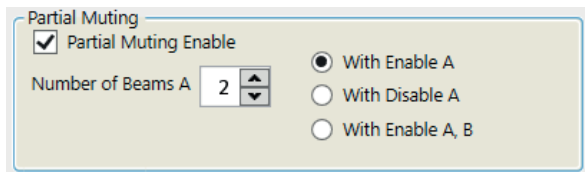

Partial Muting with Disable

When Partial Muting with DISABLE is selected, SAFEGATE enables the Partial Muting function only for the first n beams (2 in the example).

Only after a "PARTIAL Muting" signal (rising edge) occurs before the start of the Muting cycle will the Muting Normal cycle be enabled.

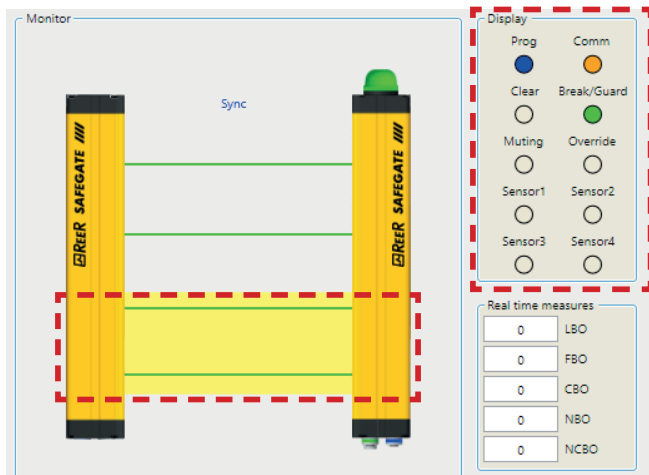
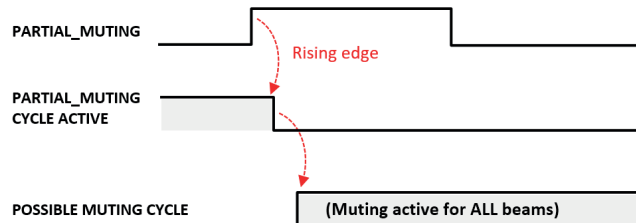
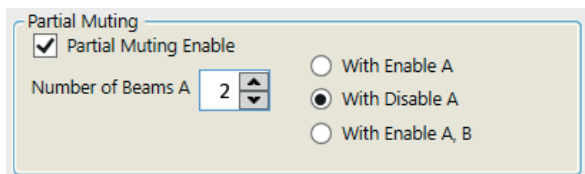

Partial Muting: MONITOR

At this stage we have a dynamic reading of the SAFEGATE condition.

In particular, are highlighted:



- A graphic representation of the curtain, with integrated lamp with colour in real time.
- A graphic representation of the signalling label.
- A graphical representation of the curtain, with highlighted beams for Partial muting function.

- ➔ **Pay attention to the two highlighted zones in the boxes: in the example, the Partial muting option for the first 2 beams was selected. THE BEAMS WITH Partial Muting FUNCTION ARE HIGHLIGHTED IN YELLOW, WHILE GREEN COLOURED BEAMS WORK NORMALLY: ACTIVE CURTAIN.**

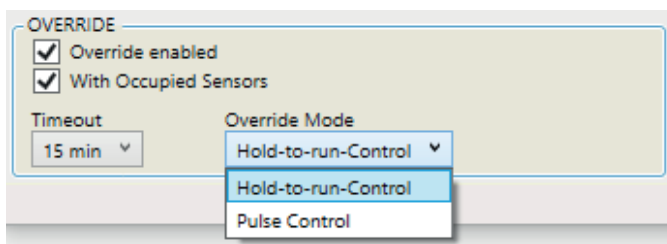
MUTING OVERRIDE



→ *The **OVERRIDE** function becomes necessary when, after incorrect Muting activation sequences, the machine stops with the dangerous hazardous material.*

-  *In this situation, the OSSD outputs are inactive because the curtain and/or at least one Muting sensor are occupied. In this condition, the **OVERRIDE** request LED flashes. This operation activates the OSSD outputs make it possible to remove the blocking material; In addition, the Override/Muting lamp flashes.*
-  *During the entire phase in which the **OVERRIDE** function is active, the Override/Muting lamp flashes. You should periodically verify the efficiency of this lamp (during Muting or Override phases).*
-  ***Warning!** The Pulse Override command automatically activates the curtain outputs until both the curtain and the Muting sensors are again free of obstacles. During this period the curtain is not able to protect access to the dangerous gate. It is therefore necessary that all operations be conducted under close supervision of experienced personnel.*

Override can only be activated if Muting is not active and at least one Muting sensor is occupied (or if the curtain is busy). At the release of the grid and sensors the Override ends.

Override can be configured in two ways:

- Hold-to-run control.
- Pulse control.

Override with Hold-to-run control

Activating this function must be done by keeping the Override command active for the duration of subsequent operations. However, it is still possible to start a new override by de-activating and re-activating the command. At the release of the grid and sensors (clear gate) or the timeout expiration, the Override terminates without additional commands.

Override with Pulse control

Activating this function occurs by activating the Override command. At the release of the curtain and sensors (clear gate) or the timeout expiration, the Override terminates. The function can only resume if the Override command is switched on again.

Parameters

With sensors occupied: When selected, the activation of at least one sensor is required to activate the **OVERRIDE** request.

Timeout: It allows you to set the time, which varies from 10 seconds to infinity, within which the function **Override** must end.

SAFEGATE DIAGNOSTIC - ERRORS

ERROR	FAILURE DESCRIPTION	ACTION
0 ÷ 25	Internal error	Return the barrier to ReeR to be repaired
34 35, 37 40, 47 49, 50	OSSD error	Verify connection of pins 3, 4 on the main connector
32, 33, 36, 38, 39, 41 42, 43, 44 45, 46, 48, 51	OSSD Internal error	Return the barrier to ReeR to be repaired
64 ÷ 73	Main board Internal error	Return the barrier to ReeR to be repaired
74, 75	Overcurrent on 24VDC	Verify max current consumption $\leq 1,6A$
76 ÷ 85 90	Main board Internal error	Return the barrier to ReeR to be repaired
86, 87	STATUS out error	Verify connection of pin 12 on the main connector
88	Overcurrent on auxiliary LAMP	Verify connection of pin 1 on the LAMP/USB connector
89	See 86, 87, 88	See 86, 87, 88
105, 106	Interfering Emitter detected	<ul style="list-style-type: none"> ➤ Switch the position of the Active and Passive elements ➤ Move the interfering Emitter to avoid this illuminating the Active element ➤ Shield the beams coming from the interfering Emitter using opaque protections
128	Configuration error	Verify connection of pins 6, 7, 8, 11 on the main connector
129	Initial configuration modified	Verify connection of pins 6, 7, 8, 11 on the main connector
130	See 128, 129	See 128, 129
131, 132	With EDM active, initial PIN 8 status wrong	Verify connection of pin 8 on the main connector
133	Stucked EDM contact (closed)	Verify external contacts
134	Open EDM contact	Verify external contacts
135	See 133, 134	See 133, 134
136	OVERRIDE configuration error	Verify connection of pins 9, 10 on the main connector
137	Exceeded max number of Override requests	Turn off and on SAFEGATE
138	See 137	See 137
139	24VDC on STATUS output	Verify connection of pin 12 on the main connector
140	Overcurrent on STATUS output	Verify connection of pin 12 on the main connector
141	See 139, 140	See 139, 140
142	Error on Integrated lamp	Return the barrier to ReeR to be repaired
143, 144	Error on Auxiliary lamp	Verify connection of pin 1 on the LAMP/USB connector
146, 147	Muting sensors configuration error	<ul style="list-style-type: none"> ➤ Verify muting sensors connection ➤ Verify position of sensor 2 with the software ➤ If no error is detected, return the barrier to ReeR to be repaired

CONTROLS, CARE AND MAINTENANCE

PRE-ACTIVATION CHECKLIST

➔ *To make sure that SAFEGATE has been configured correctly, follow the following checklist before turning on the product for the first time.*

1. Verify that the electrical connections have been carried out correctly.
2. Verify that the supply voltage is 24Vdc \pm 20% (PELV, compliant with EN 60204-1 (Chapter 6.4)).
3. Verify that access to the hazardous area can only take place through the gate protected by SAFEGATE.
4. Verify that there are physical protection curtains preventing access to the hazardous area.
5. The power contactors operating the hazardous machine must meet the safety level off the grid: SIL 3 - PL and - Cat.4.
6. RESTART and OVERRIDE commands must not be accessible from inside the hazardous area.
7. The minimum safety distance must have been previously measured and respected during installation.
8. There must be no reflective surfaces near the dangerous area.
9. Make sure that the MUTING/OVERRIDE signal lamp is installed in a visible location by the operator.
10. Ensure that there are no spurious light sources that may affect the smooth operation of the SAFEGATE.
11. Make sure the on-board staff has been adequately trained on the SAFEGATE operation.

PERIODIC CONTROL

 *Functional checks must be carried out at a certain frequency (e.g. daily), depending on the risk analysis and the grid utilization environment.*

1. Verify that Active and Passive Elements have been properly connected to the power supply. (24VDC \pm 20%).
2. Verify (only if SAFEGATE is programmed via Software) that the blue LED "PRG" is lighted on.
3. Verify the correct configuration settings:
 - a) **MANUAL:**

At power-up, the curtain waits for a RESTART command to activate its work cycle (START INTERLOCK). Verify that this command is positioned so that it cannot be activated from the inside of the hazardous area. Stop at least one beam of the protected area and make sure that the red LED  on the Active element (RESTART INTERLOCK) lights up.
 - b) **AUTOMATIC:**

Stop at least one beam of the protected area and verify that the green LED  is lit again on correct operation (beams free).

4. Verify protected zone:

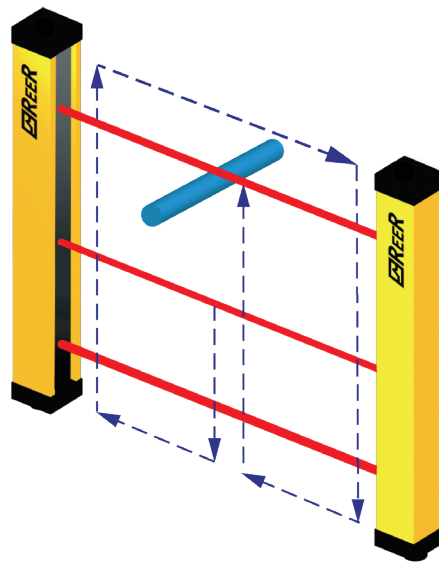



- a) Interrupt with one opaque object every beam in the centre and then close to both the Active and Passive Element.
- b) Check that at each stage of the test object movement the red LED on the Active Element remains in any case switched on and that the dangerous machine stops.

CARE AND MAINTENANCE

SAFEGATE does not require any specific maintenance work; however, periodic cleaning of the frontal protection surfaces of the two devices is recommended.

Cleaning should be carried out with a damp cloth; In particularly dusty environments, after cleaning the front surface, it is advisable to spray it with an anti-static product.

-  ***In any case, do not use abrasive, corrosive, solvents or alcohol that could damage the part to be wiped or wool cloth to avoid electrostatically loading the front surface of the curtain itself.***
-  ***Even a very fine groove of frontal plastic surfaces can increase the width of the beam of the light curtain, thus compromising the effectiveness of detection in the presence of reflective lateral surfaces.***
-  ***It is therefore essential to pay particular attention during the cleaning steps of the curtain front window, particularly in environments where abrasive powders are present. (e.g. cement plants, etc.).***

WARRANTY

REER guarantees that every new SAFEGATE system is free from defects in materials and manufacturing for a period of 12 (twelve) months from the time it is released by the factory if used under normal conditions. During this period, REER is committed to eliminate any defects in the product by repairing or replacing defective parts, completely free of charge, both for material and labour.

However, REER reserves the right to proceed, instead of repairing it, to replace the entire defective equipment with one having the same or equal characteristics.

The validity of the warranty is subject to the following conditions:

- ➔ ***The failure must be reported by the user to REER within twelve months from the date of delivery of the product.***
- ➔ ***The equipment and its components are in the same condition as delivered by REER.***
- ➔ ***Failure or malfunction has not originated directly or indirectly from:***

- Use for inappropriate purposes;
- Failure to comply with the rules of use;
- Negligence, lack of expertise, incorrect maintenance;
- Repairs, modifications, adaptations not performed by REER personnel, tampering, etc.;
- Accidents or shocks (even if due to transport or causes of force majeure);
- Other causes independent of REER.

The repair will be carried out at the REER laboratories where the material must be delivered or shipped: the shipping costs and the risks of any damage or loss of material during shipment are the responsibility of the customer.

All replaced products and components become REER property.

REER does not recognize any other warranties or rights except those expressly described above; in no case can claims for damages for expenses, activity interruption, or other factors or circumstances be made in any way related to the failure of the product or one of its parts.

The strict and complete observance of all the standards, indications and prohibitions set forth in this manual is an essential requirement for the proper operation of the light curtain. REER s.p.a., therefore, disclaims any liability in case of non-respect, even partial, of these indications.

Features subject to change without notice. • Full or partial reproduction is prohibited without REER's permission.